



# Modeling, Simulation and Analysis, and High Performance Computing Force Multiplier for American Innovation

Final Report to the U.S. Department of Commerce Economic Development Administration  
on the National Digital Engineering Manufacturing Consortium (NDEMCM)



**Compete.**

Council on  
Competitiveness



# Table of Contents

Executive Summary	4
Results and Lessons Learned	7
MS&A and HPC Force Multiplier for American Innovation	8
Launching the NDEMC	11
History and Legacy of Council HPC Leadership	15
Advocacy of Advanced Computing and Manufacturing	18
NDEMC—Midwest’s Demonstration Projects	20
NDEMC Partner Spotlight	24
NDEMC A Win–Win Partnership	27
Economic Impact of the NDEMC	28
Findings and Lessons Learned	29
Next Steps and Future of NDEMC Initiatives	33
Acknowledgements	34
Appendix A	35
Appendix B	41
Appendix C	66

# Executive Summary

Ninety-seven percent of U.S. manufacturing firms—more than a quarter-million of them—have fewer than 500 employees.<sup>1</sup> While most U.S. manufacturers are small, they play a large role in U.S. innovation. Of high patenting firms, small firms in the United States produce 16 times more patents per employee than large patenting businesses.<sup>2</sup> Their patents are twice as likely to be technologically important, making their innovations more leading edge.<sup>3</sup> Small firms tend to specialize in high technology, high growth industries such as biotechnology, pharmaceuticals, IT, and semiconductors.<sup>4</sup> Large firms increasingly depend on small firms for new ideas and new technologies. They invest in start-ups, acquire small innovative companies, and partner with small firms to develop new products.

To maintain the U.S. edge in the hyper-competitive global economy in the decades ahead, manufacturers must improve the design, development and deployment of next generation products, production technologies, tools, and processes. “Democratizing the use of high fidelity software and appropriate computing tools for all U.S. manufacturers will increase U.S. economic competitiveness globally,” said The Honorable Aneesh Chopra, former Chief Technology Officer to President Obama.

High-fidelity modeling, simulation and analysis (MS&A) tools and high performance computing (HPC) offer an extraordinary opportunity for the United States to design products faster, minimize the time to create and test prototypes, streamline production processes, lower the cost of innovation and develop high-value innovations that would otherwise be impossible.

1 Number of Firms, Number of Establishments, Employment, and Annual Payroll by Enterprise Employment Size for the United States, All Industries 2010, 2010 County Business Patterns, U.S. Bureau of the Census.

2 U.S. Small Business Administration FAQs.

3 Small Serial Innovators and The Small Firm Contribution to Technology, U.S. Small Business Administration, February 2003.

4 An Analysis of Small Business Patents by Industry and Firm Size, U.S. Small Business Administration, November 2008.

## NDEMC Pilot Results

- 20 projects, 16 carried to completion
- 160 new jobs created
- Over \$20 million in new annual sales
- Roughly \$10 million in exports
- Three new products
- One patent application

## Results Projected to 1,000 U.S. Small Manufacturers

- 8,000 new jobs created
- Over \$1 billion in new annual sales
- Roughly \$500 million in exports
- 150 new products
- 50 patent applications

Driving MS&A/HPC throughout the U.S. supply chain, and putting these powerful tools into the hands of SMEs would transform what they do. “Widespread deployment across the U.S. industrial landscape would dramatically enhance the U.S. ability to innovate, accelerate the development and commercialization of new products, and significantly improve manufacturing productivity, driving U.S. economic growth, new job creation, and global market competitiveness,” said former Assistant Secretary for the U.S. Department of Commerce Economic Development Administration, John Fernandez.

MS&A provides a productivity and competitive advantage for many large U.S. manufacturers. Unfortunately, small and medium-sized U.S. enterprises (SMEs) make very limited or no use of MS&A/HPC. They lack the internal expertise and support network that would allow them to fully exploit MS&A/HPC and achieve its competitive benefits.

On March 2, 2011, the White House announced the creation of a public-private partnership to improve small and medium size manufacturers productivity through education, training and to provide expertise in the use of high-end MS&A (see Appendix A).

### The National Digital Engineering and Manufacturing Consortium

In December 2008, the Obama Science and Technology Transition Team requested a meeting with the Council on Competitiveness to discuss opportunities for the use of High Performance Computing to impact the U.S. economy. So began the Council's advocacy to create a public-private partnership targeting the use of HPC modeling, simulation and analysis by U.S. manufacturers to increase innovation, productivity and job creation. Throughout 2009-2010, this effort was actively championed by Council HPC Advisory Members: Richard Arthur, GE Global Research; Keven Hofstetter, Caterpillar, Inc.; Tom Lange, Procter & Gamble Company; Paul Fussell, Boeing; Don Lamb, University of Chicago; and Merle Giles, University of Illinois. These individuals formed the HPC Manufacturing Working Group.

The Group met with U.S. government officials to inform them about the impact that HPC could deliver to U.S. manufacturers, large and small. Meetings with Secretary of Energy Dr. Steven Chu, Department of Energy Under Secretary for Science Dr. Steven Koonin, U.S. Chief Technology Officer Aneesh Chopra, National Science Foundation Director Dr. Arden Bement, Assistant Secretary for Economic Development John Fernandez, Assistant Secretary for Communication and Information and NTIA Administrator Lawrence Strickling, and U.S. Chief Information Officer Vivek Kundra. Over the same time period, the Council produced five white papers informed by the HPC Manufacturing Working Group (see Appendix B).



*Mr. Bruce Brown, Chief Technology Officer, Procter & Gamble; the Honorable Deborah L. Wince-Smith, President & CEO, Council on Competitiveness; and Dr. Ray O Johnson, Senior Vice President & Chief Technology Officer, Lockheed Martin appear at the White House MOU signing ceremony for NDEMC in March 2011.*

In February 2010, the Council convened a Roundtable Summit on HPC and U.S. Manufacturing. The Roundtable brought together U.S. manufacturers, the Department of the Treasury, the President's Office of Science and Technology Policy, the Department of Energy, the National Science Foundation, the National Aeronautics and Space Administration, the Department of Defense, Congressional staff, universities, national laboratories, and others to discuss challenges and opportunities for HPC to improve U.S. manufacturing.

President Obama's first ever Manufacturing Czar, Ron Bloom, embraced the Council's initiative to launch a new industry-led, public-private supercomputing partnership to support a robust, agile, and globally competitive U.S. supply chain—the National Digital Engineering and Manufacturing Consortium (NDEMC). The Council led this initiative based on a scalable model that leverages the resources and expertise of private industry and university partners to help SMEs drive MS&A/HPC into their design and production operations. Key corporate leaders supporting education and training of MS&A to



*Mr. Sean McClure, Procurement Analyst, U.S. Department of the Treasury and former Senior Policy Advisor, Manufacturing, The White House; and Dr. Tarek El-Ghazawi, Director, High Performance Computing Lab, George Washington University at the Council on Competitiveness Roundtable Summit on HPC & U.S. Manufacturing, February 2010.*



*Mr. Richard Arthur, Manager, Advanced Computing Lab, Computational Sciences & Architectures, GE Global Research, George Washington University at the Council on Competitiveness Roundtable Summit on HPC & U.S. Manufacturing, February 2010.*

manufacturers were Bruce Brown, Chief Technology Officer, the Procter & Gamble Company; Klaus Hoehn, Vice President, Advanced Technology & Engineering, Deere & Company; Mark Little, Senior Vice President, Director of Global Research, and Chief Technology Officer, General Electric Company; and Ray O Johnson, Senior Vice President and Chief Technology Officer, Lockheed Martin. The initiative's university partners included Purdue University, the Ohio Supercomputer Center, and the National Center for Supercomputing Applications at the University of Illinois. Additional partners were the National Center for Manufacturing Sciences, Argonne National Laboratory, and NASA Glenn. Taken together, NDEM marshaled a rich and impressive set of capabilities, expertise, and leadership to support the SME participants as they implemented MS&A/HPC in their operations.

The Original Equipment Manufacturer partners value the way these partnerships stimulate mutually beneficial collaboration and community formation that likely would not occur otherwise, despite the mutual interests. Each of the non-SME NDEM partners contributed resources to the project, and it was noted that this ownership of the project made for better engagement and cooperation.

## NDEM Midwest Demonstration Projects

The Council brought Original Equipment Manufacturers together—matching funds from the U.S. Department of Commerce's Economic Development Administration to launch NDEM in July 2011, focusing its efforts in the manufacturing-heavy U.S. Midwest—in a pilot program called the NDEM-Midwest Project. NDEM was intended to operate as a pilot program for 18 months, as the first phase of a five-year effort. The demonstration phase of the program was extended for an additional six months and came to a close in June 2013.

NDEM-Midwest involved 20 demonstration projects that offered SMEs access to MS&A/HPC tools and support services as an affordable “software-as-a-service,” sometimes referred to as a “pay-by-the-use” model. Four projects were not completed for lack of support from the SMEs' operational personnel and corporate management.

Although the NDEM Midwest Pilot was very successful, NDEM partners agree that experimentation will be necessary.

# Results and Lessons Learned

NDEMC partners and SMEs involved in demonstration projects concluded that the NDEMC-Midwest pilot project was a successful “proof of concept.” It demonstrated that when SMEs have access to MS&A/HPC, they are able to create or improve products, and processes that, in fact, make them more competitive.

NDEMC determined that the NDEMC-Midwest Pilot was responsible for creating more than 160 new jobs in 2012, increased sales by more than \$20 million/year, and the SMEs developed three new products. Using the group of SMEs that participated in the demonstration as a microcosm, if NDEMC could reach out and apply its model to 1,000 SMEs, it would be reasonable to expect those engagements to result in 150 new products, 50 new patent applications, \$1 billion in new sales, and 8,000 new hires. These projected results would be from 1,000 SMEs out of the 250,000 smaller manufacturers in the United States.

The NDEMC partners identified “lessons learned” that should guide future NDEMC efforts:

- Public-private partnerships are an essential model for projects where new infrastructure or “industrial commons” need to be developed to support an entire industry sector.
- The NDEMC partnership proved to be a valuable new learning platform for all participants.
- SMEs cannot justify and are unwilling to purchase expensive MS&A/HPC tools, but are willing to buy access to MS&A/HPC, consulting, and training on a pay-by-the-use model.
- Encouraging MS&A/HPC Independent Software Vendors to deploy Software-as-a-Service could drive wider access to MS&A/HPC tools for U.S. SMEs.
- The opportunity to “reduce time-to-market for products” is a critical factor in SMEs’ decision to participate in NDEMC.
- Senior management, engineering, and operations personnel need to “buy-in” to projects. Defining clear project goals and expected outcomes, and conveying them from the top down is critical. The time and effort required to engage in an MS&A/HPC project must be transparent, and a strong business case for participating in a project must be developed upfront.
- SMEs need significant hands-on support and training to realize fully the potential of incorporating MS&A/HPC into their business operations. This includes a trusted third party to help educate them on MS&A/HPC, and to provide ongoing guidance and support to assist them in developing solutions that they can apply in their business.
- More in depth project definition and planning is required by NDEMC leadership to understand full costs associated with each SME project.
- A robust, “industrial strength” portal/marketplace is required to operate the NDEMC model efficiently and successfully.



*Mr. Merle Giles, Director, Private Sector Program and Economic Development, The National Center for Supercomputing Applications (NCSA), the University of Illinois at Urbana-Champaign, speaks during the 2013 NDEMC Modeling & Simulation Workshop at NCSA.*

# MS&A and HPC Force Multiplier for American Innovation

## Introduction

To maintain the U.S. edge in the hyper-competitive global economy in the decades ahead, manufacturers must improve the design, development, and deployment of next generation products, production technologies, tools, and processes. High fidelity modeling, simulation and analysis (MS&A) tools and High Performance Computing (HPC) offer an extraordinary opportunity for the United States to design products faster, minimize the time to create and test prototypes, to streamline production processes, lower the cost of innovation, and develop high-value innovations that would otherwise be impossible.

MS&A/HPC powers incredible innovation. Thousands of microprocessors and accelerators work together to mimic physical reality. They can focus on a single water molecule or an entire ocean, and make sense of data collected from billionths of a second or billions of years. Whether it is the aging of a nuclear weapon or the aerodynamics of a potato chip moving along a production line, simulations reveal details and complex relationships with stunning clarity. U.S. innovators have long been the world's most prolific and, with MS&A/HPC, we can multiply this innovative force.

MS&A provides a competitive advantage for many U.S. global manufacturing leaders. These large companies employ in-house advanced computing and have access to HPC hardware, software, and technical resources both internally and through partnerships with U.S. national laboratories and universities. Their digital manufacturing infrastructure spans from advanced engineering design to modeling of production processes in manufacturing. These capabilities have decreased time-to-market for new products, enhanced production throughput, reduced

*Force multiplier...a factor that dramatically increases the effectiveness of a given force.*

waste, increased safety and sustainability, and generated critical information to inform decision-making. Unfortunately, MS&A/HPC remain largely the tools of these big companies and researchers. There are relatively few experienced MS&A/HPC users in U.S. industry, and many businesses don't use it at all.

Small and medium-sized enterprises (SMEs) especially make very limited or no use of MS&A/HPC. They lack the internal expertise and support network that would allow them to move up the learning curve to fully exploit MS&A/HPC. This includes access to experts and advisors, affordable commercial MS&A software, hardware infrastructure, and the rich external R&D resources and capabilities in U.S. universities and national laboratories.

Ninety-seven percent of U.S. manufacturing firms—more than a quarter-million of them—have fewer than 500 employees.<sup>5</sup> While most U.S. manufacturers are small, they play a large role in U.S. innovation. Of high patenting firms, small firms in the United States produce 16 times more patents per employee than large patenting businesses.<sup>6</sup> Their patents are twice as likely to be technologically important, making their innovations more leading edge.<sup>7</sup> Small firms tend to specialize in high technology, high growth industries such as biotechnology, pharmaceuticals,

5 Number of Firms, Number of Establishments, Employment, and Annual Payroll by Enterprise Employment Size for the United States, All Industries 2010, 2010 County Business Patterns, U.S. Bureau of the Census.

6 U.S. Small Business Administration FAQs.

7 Small Serial Innovators The Small Firm Contribution to Technology, U.S. Small Business Administration, February 2003.



*The Honorable Deborah L. Wince-Smith, President & CEO, Council on Competitiveness; The Honorable, Gene Sperling, President's Economic Council of Advisors; and Jason Miller, President's Advisor, Office of Manufacturing Policy.*



*The Honorable Deborah L. Wince-Smith, President & CEO, Council on Competitiveness; the Honorable Ron A. Bloom, former Assistant to the President for Manufacturing Policy, The White House; and the Honorable John Fernandez, former Assistant Secretary, Economic Development Administration (EDA), U.S. Department of Commerce; appear at the White House Announcement for the EDA grant in March 2011.*

IT, and semiconductors.<sup>8</sup> Large firms increasingly depend on small firms for new ideas and new technologies. They invest in start-ups, acquire small innovative companies, and partner with small firms to develop new products.

Putting MS&A/HPC in the hands of SMEs would transform their competitiveness and improve the U.S. supply chains and innovation ecosystems of large firms. Widespread deployment across the U.S. industrial landscape would dramatically enhance the U.S. ability to innovate, accelerate the development and commercialization of

new products, and improve manufacturing productivity, driving U.S. economic growth and global market competitiveness.

The federal government has recognized that, in partnership with large private sector users of MS&A/HPC, it can help create the foundation for achieving enormous economic and social benefits by lowering barriers to use of these tools and catalyzing an industrial MS&A/HPC commons for the U.S. supply chain.

<sup>8</sup> An Analysis of Small Business Patents by Industry and Firm Size, U.S. Small Business Administration, November 2008.

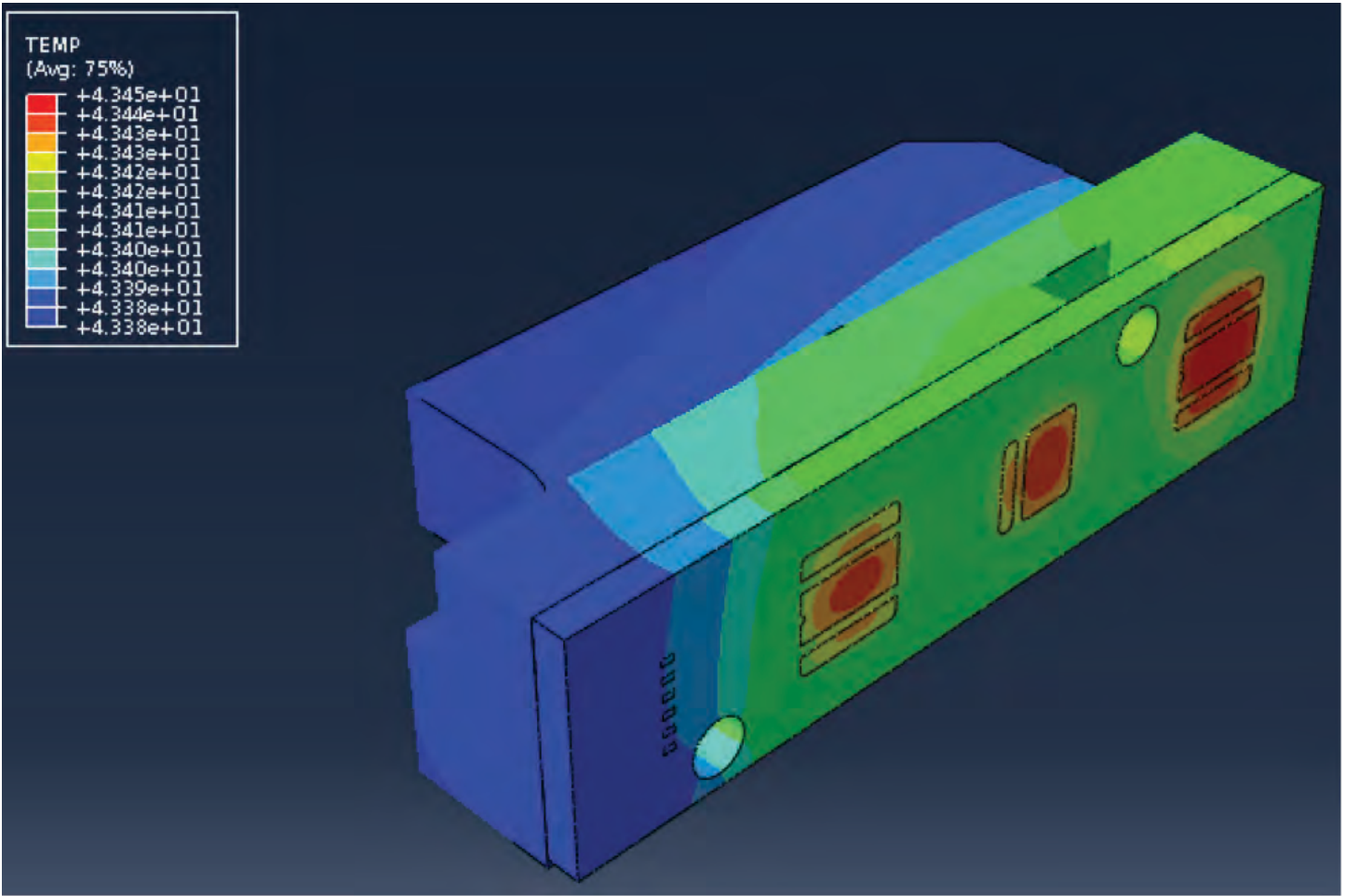

*The Ohio Supercomputer Center developed a web-based app that provides a problem-specific graphical interface to the Simulia Abaqus modeling and simulation software. Greenlight Optics leveraged the app to evaluate the capabilities of a device to dissipate heat from electronic components, based upon material properties and structural design.*

# Launching the NDEMC

President Obama's first ever Manufacturing Czar Ron Bloom embraced the Council's initiative to form a new industry-led supercomputing partnership to support a robust, agile, and globally competitive U.S. supply chain. The long-term vision for this initiative—the National Digital Engineering and Manufacturing Consortium (NDEMC)—is to create a self-sustaining non-profit entity that offers expertise, software, and hardware to support SMEs across the country.

## The NDEMC Partnership

Based on a Council framework paper from 2010, the Council envisioned a scalable model that would leverage the resources and expertise of private industry and university partners to help SMEs incorporate MS&A/HPC into their design and production operations to improve product quality, provide greater customization, and deliver financial growth. The Council created, drove, led this initiative and forged alliances with four original equipment manufacturers (OEMs) that have been instrumental in developing NDEMC's public-private partnership model.

The initiative's main industry partners include stakeholders Deere & Company, General Electric Company, Lockheed Martin Corporation, and the Procter & Gamble Company. Participating SMEs have benefitted from the HPC expertise and other technical capabilities from the program's university partners, which include Purdue University, the Ohio Supercomputer Center, and the National Center for Supercomputing Applications at the University of Illinois, Argonne National Laboratory, and the National Aeronautics and Space Administration (NASA).

NDEMC engaged SME partners seeking affordable access to HPC platforms and to advance their use of existing MS&A. These tools would enable them to improve productivity and time-to-market for their products by increasing the accuracy of their calculations, decreasing the time to solution, and reducing design and production cycles. Larger OEMs acted as both shareholders and



*Dr. Mark M. Little, Senior Vice President & Chief Technology Officer, General Electric Corporation, and Director, GE Global Research; and Dr. Pradeep Khosla, Chancellor, University of California, San Diego; during a 2011 meeting of the Council's Technology Leadership and Strategy Initiative (TLSI).*

project participants through funding, in-kind contributions, and assistance in identifying SME candidates for the program.

NDEMC marshaled a rich and impressive set of capabilities, expertise, and leadership support from global firms, federal agencies, world-class national laboratories, state governments, and leading universities. These resources played a critical role in supporting the SME participants as they implemented MS&A/HPC in a variety of demonstration projects.

## NDEMC Leadership and Management Team

NDEMC is led by an Executive Board established to provide program oversight and direction. Executive Board members have included representatives from Lockheed Martin Corporation, Deere & Company, GE Energy, Procter & Gamble Company, the Ohio Board of Regents, and the Council on Competitiveness, which also serves as the

**NDEMC PARTNERS****OEM Industrial Partners**

The Procter & Gamble Company  
(P&G)

Lockheed Martin Corporation

General Electric Company

Deere & Company

**Solution Partners**

Ohio Supercomputer Center (OSC)

National Center for Supercomputing  
Applications (NCSA)

Purdue University

National Center for Manufacturing  
Sciences (NCMS)

SCRA/ATI

Council on Competitiveness

**Federal Government**

White House (National Economic  
Council, Office of Manufacturing  
Policy, OSTP)

U.S. Department of Commerce  
(EDA)

U.S. Department of Energy (Argonne  
National Laboratory)

National Institute of Standards and  
Technology (NIST)

National Aeronautics and Space  
Administration (NASA)

National Science Foundation (NSF)

**State Governments**

State of Ohio (Ohio Board of  
Regents)

State of Indiana



imagination at work



Ohio Supercomputer Center



U.S. ECONOMIC DEVELOPMENT ADMINISTRATION



**LOCKHEED MARTIN**



**JOHN DEERE**



National Center for  
Manufacturing Sciences



**Compete.**

Council on  
Competitiveness

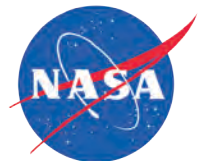

University System of Ohio  
Board of Regents

NDEMC Secretariat. A Technical Program Manager was retained by the NDEMC Executive Board to execute day-to-day technical oversight and management of NDEMC operations.

The Management Team is guided by a business plan that aims to develop NDEMC into a self-sustaining entity. Throughout the Midwest Pilot, the management team stayed in close communication through weekly conference calls, monthly reports from the Project Technical Manager, team meetings, and Executive Board and all-hands meetings every four to six months. The NDEMC partners—government, OEMs, and solution providers—cited weekly teleconferences and timely meeting minutes as a key contributor to the cohesiveness of the NDEMC team.

### Operating Model for Delivering MS&A/HPC Resources to SMEs

NDEMC delivered a model that made MS&A/HPC tools and support affordable and accessible to SMEs. The model demonstrated that there can be a substantial return for SMEs investing time and resources in MS&A/HPC - a first step toward establishing a functioning private market for these tools and services.

A key innovation supported by NDEMC was a new way for SMEs to utilize critical software affordably. By establishing the first ever public private partnership encouraging “software-as-a-service” (SaaS), or “pay-by-the-use” model, SMEs gained an alternative to purchasing software licenses. Purchasing such licenses often did not make economic sense for smaller firms. Under the new SaaS model, SMEs could purchase access to software as needed for a particular project.

NDEMC partners also supported the model by:

- Identifying candidate SMEs through the local NIST Manufacturing Extension Partnership Centers;
- Pairing SMEs with university faculty, staff, and students;
- Introducing SMEs to the simulation software domain experts; and
- Creating web-delivered educational materials for SMEs.

Each approach was successful. Close connections with the SMEs were instrumental in transferring MS&A technology and capabilities effectively, and in the use by SMEs for innovation and product design.

The OEMs varied in the level of hands-on involvement with the SMEs they brought to participate with NDEMC. In some cases, the OEM put the SME in touch with one

### EXECUTIVE BOARD



**Bryan Dods**  
Executive, Manufacturing Engineering & Technology  
GE Power & Water



**William Flite**  
Senior Manager, Hardware Engineering and Advanced Manufacturing  
Lockheed Martin



**Thomas Lange**  
Director, R&D, Modeling & Simulation, Global Capability Organization (M&S GCO)  
The Procter & Gamble Company



**Edward Morris**  
Lockheed Martin (currently at America Makes)



**Alice Popescu-Gatlan**  
Director, John Deere Technology Innovation Center  
Deere & Company



**Dwayne G. Sattler**  
Associate Vice President for Policy  
Office of Research Ohio Technology Consortium (OH-TECH)  
The Ohio State University  
Ohio Board of Regents



*Mr. Rob Neely, Computer Scientist, Lawrence Livermore National Laboratory; former Computer Scientist in Residence, Council on Competitiveness; Mr. Merle Giles, Director, Private Sector & Economic Development, National Center for Supercomputing Applications (NCSA), University of Illinois at Urbana-Champaign; the Honorable Aneesh Chopra, former U.S. Chief Technology Officer; Dr. Donald Q. Lamb, Louis Block Professor of Astronomy & Astrophysics, University of Chicago; Mr. Sean McClure, Procurement Analyst, U.S. Department of Treasury and former Senior Advisor for Manufacturing Policy, The White House; the Honorable Brian P. McGowan, former Deputy Assistant Secretary, Economic Development Administration (EDA), U.S. Department of Commerce; the Honorable Deborah L. Wince-Smith, President & CEO, Council on Competitiveness; Dr. Cynthia R. McIntyre, Senior Vice President, Council on Competitiveness; the Honorable Ron A. Bloom, former Assistant to the President for Manufacturing Policy, the White House; the Honorable John R. Fernandez, former Assistant Secretary, Economic Development Administration (EDA); Mr. Richard B. Jarman, President & CEO, National Center for Manufacturing Sciences (NCMS); Dr. David McKinnis, Director, Technical Assistance Program (TAP) & Vice President for Engagement, Purdue University; Dr. Ashok Krishnamurthy, former Interim Co-Executive Director & Senior Director of Research, Ohio Supercomputer Center.*

of the solution partners, and execution of the project was the sole responsibility of those two organizations. In another case, the OEM contributed technical consulting and the use of sophisticated measurement equipment. In one case, the OEM assembled an ad hoc working group spanning its divisions to support an SME project with considerable technical challenge and business significance.

### Gateway to MS&A/HPC

A core requirement for the NDEMC model was a portal to support the SaaS model, creating web access to the project's MS&A/HPC resources. After determining through a formal Request for Information that there were no commercially available portals with features that could meet its needs, an NDEMC Portal Committee led by Argonne National Laboratory directed the development of a prototype portal using the commercially avail-

able Nimbis platform. Created and configured through a contract with Nimbis and OSC, the prototype was tested and evaluated. The Portal Committee determined that, when new NDEMC funding is available, a robust, industrial strength portal could be developed to support an expanded NDEMC program.

### Outreach and Communications Strategy

NDEMC created a number of vehicles and channels for communicating its messages to the marketplace. The most effective communications tools have been its website, NDEMC.org; a SharePoint site for communications among the NDEMC team and for use as an information and document repository; and the participation of NDEMC leaders and staff as speakers and panelists at a range of manufacturing conferences (Supercomputing 2012, International Supercomputing 2013, etc.)

# History and Legacy of Council HPC Leadership

More than a decade of Council leadership is hardwired into today's NDEMC.

In 2003, the Council created the first public-private partnership to ensure sustained U.S. leadership in high performance computing. Also, the partnership aimed to leverage HPC to strengthen U.S. productivity, scientific and technological supremacy, and national security. Government agencies invested in the Council to carry out this mission, including the U.S. Department of Energy, the Defense Advanced Research Projects Agency and the National Science Foundation.

The Council mobilized senior leaders across industry, academia and the national laboratories, establishing the High Performance Computing Advisory Committee (HPCAC). The HPCAC made the business case for U.S. leadership in HPC and advised the government how federal investments in HPC could create new competitive advantage and opportunities for U.S. industry. The HPCAC produced case studies on grand challenges that could be addressed by HPC, organized sector-specific industry workshops and hosted annual HPC users' conferences. The HPCAC confers regularly with members of Congress and senior administration officials, recommending investment and legislative priorities. The Council has harnessed the collective knowledge of this unique cross-sectorial HPC brain trust to educate national leaders, disseminate knowledge, and take action that strengthens the competitiveness of U.S. companies. The Council has built a substantial body of analysis and case studies demonstrating the economic value of HPC



*Dr. Walter Kirchner, Institutional Liaison Manager, Argonne National Laboratory & former Chief Technologist in Residence, Council on Competitiveness and the Council's HPCAC Co-Chair, the Honorable Steven Koonin, Founding Director, Center for Urban Science and Progress, Leonard N. Stern School of Business, New York University, appear at a Council HPCAC meeting in 2013.*

modeling, simulation and analysis—making the case that *To Out Compete is to Out Compute.*<sup>™</sup>

In 2004, the Council hosted U.S. Secretary of Energy Spencer Abraham and members of Congress to announce a \$50 million Leadership Class Computing Competition designed to ensure that the United States maintained the most advanced computing capabilities in the world. Also, the Council created the policy and business guidelines for the Innovative and Novel Computational Impact on Theory and Experiment (INCITE) program that enabled U.S. industry to compete

*Through determined efforts, the Council has built an unparalleled network in government, industry, academia, and the national laboratories—serving as America's brain trust to maintain and grow U.S. HPC world leadership.*



*Mr. Thomas Guevara, Deputy Assistant Secretary for Regional Affairs, Economic Development Administration (EDA), Department of Commerce; Ms. Alice Popescu-Gatlan, Director, John Deere Technology Innovation Center; Mr. Craig Carlson, President and CEO, Jeco Plastic Products Inc.; Mr. Paul Domagala, Knowledge Management Officer, Argonne National Laboratory; and Mr. Merle Giles, Director, Private Sector Program and Economic Development, The National Center for Supercomputing Applications (NCSA), the University of Illinois at Urbana-Champaign, discuss the NDEM public-private partnership in June 2012 on Capitol Hill.*

for access to U.S. government supercomputers. This was a major step forward as the INCITE program had been restricted to academic and government researchers. To demonstrate the power of HPC to transform the lives of all Americans, the HPCAC produced an entertaining, informative video with DreamWorks Animation, explaining how multiple industries and the nation benefit from HPC. This effort took advantage of advanced animation technologies used by the entertainment industry, which relies on HPC.

The Council also elevated the HPC imperative to the presidential level. In his 2006 State of the Union Address, President George W. Bush advocated doubling the federal

commitment to basic research over 10 years to “explore promising areas such as nanotechnology, supercomputing, and alternative energy sources.”

The Council pushed to extend MS&A throughout the U.S. supply chain to drive manufacturing competitiveness, and the Council defined deficiencies in the software market for wider MS&A adoption. The Council continues to drive these agendas today.

The Council's long track record of HPC leadership and results prompted the Obama Science and Technology Transition Team to seek the HPCAC's advice in 2008. The resulting white papers informed the Administration's strategy and positioning of HPC in economic recovery.

**2003-04 Formation of HPC Advisory Committee**

**2006 President calls out supercomputing in State of the Union Address**

**2009 Council meets Energy Secretary Chu on steps to expand modeling & simulation**

**2009 Council publishes case studies on industrial uses of HPC**

**2005 Council teams with DreamWorks to promote HPC competitiveness value**

**2008 Obama transition team reaches out to Council for HPC policy advice**

**2011 White House announces award for NDEMC to bring HPC modeling and simulation to SMEs in the Midwest.**

**2004 1<sup>st</sup> Council HPC Users Conference**

**2006-07 Council partners with DOE to offer HPC computing resources to industrial users (INCITE program)**

**2004** **2005** **2006** **2007** **2008** **2009** **2010** **2011** **2012**

**Compete, Council on Competitiveness**

**NDEMC**



Council HPCAC Co-chairs Ms. Dona Crawford, Associate Director, Computation, Lawrence Livermore National Laboratory (LLNL), and Dr. Michael McQuade, Senior Vice President for Science & Technology, United Technologies Corporation (UTC) participate in an Extreme Computing panel at the July 2013 Capitol Hill Briefing in Washington, D.C.

# Advocacy of Advanced Computing and Manufacturing

## U.S. Council on Competitiveness 2008-2013

2008

Obama Science & Technology Transition Team met with Council for guidance on HPC use to stimulate economic growth

March 2009

President & CEO Deborah Wince-Smith, Senate Committee Energy & Natural Resources Energy Research & Development Testimony

2009-2012

NSF, NIST, NITRD, DOE, DOC, OSTP, Treasury, OMB meetings

2008

### COUNCIL ON COMPETITIVENESS POSITION PAPERS

2009

January 2009



2010

March 2009

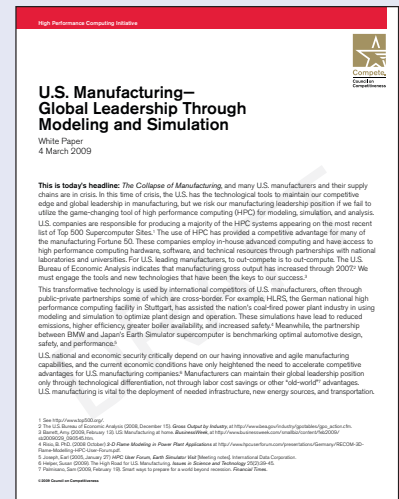

### DMDII CONCEPTS INTRODUCED

March 2009

U.S. Manufacturing—Global Leadership Through Modeling and Simulation

#### Recommendations & Motivations

- National & economic security critically depend on innovative and agile manufacturing
- Create national manufacturing initiative enabled by advanced computing
  - Simulation-based manufacturing
  - Virtual Engineering
  - Reduce test costs, certification costs, design cycle time, waste
  - Model complex systems



February 2010

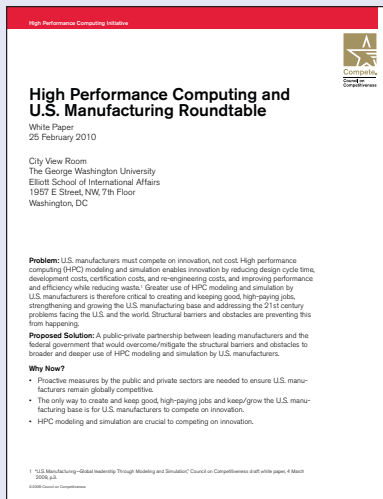

August 2010



September 2010

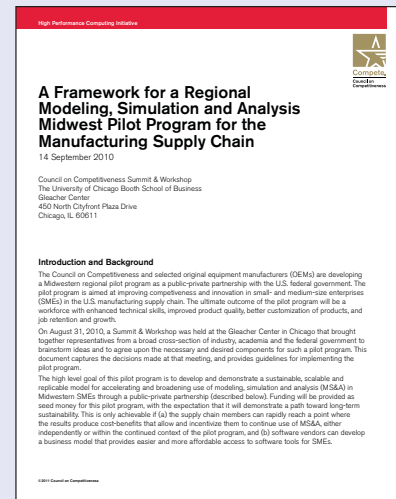

February 2010

HPC and U.S. Manufacturing Roundtable at GWU (Note: DOD & US Army participation)

- US Manufacturers must compete on innovation, not cost
- Computational modeling/simulation crucial to compete on innovation: reduces cycle time, development costs, certification costs, re-engineering costs, improve performance while reducing waste.

- Form industry + government partnership to overcome/mitigate barriers to broaden/ deepen use of HPC modeling/simulation in US manufacturing, key enablers:
  - High speed internet
  - Capstone simulation enablement
  - Verification & validation
  - IP protections (codes, data)
  - Access to national lab codes
  - Creation & growth of scalable multiphysics codes

# NDMEC–Midwest’s Demonstration Projects

On March 2, 2011, the White House announced that the Council would lead the first public-private partnership of the Obama Administration, focused on SME advanced manufacturing capability. At the White House ceremony to sign the Memorandum of Understanding, the Administration was represented by Manufacturing Czar Ron Bloom, U.S. Chief Technology Officer Aneesh Chopra, U.S. Assistant Secretary for Economic Development John Fernandez, Deputy Assistant Secretary of Energy Steven Koonin, NASA Chief Technologist Robert Braun, NIST Associate Director Phillip Singerman and NSF Assistant Director Thomas Peterson.

NDEMC was intended to operate as a pilot program for 18 months, as the first phase of a five-year effort. The demonstration phase of the program was extended for an additional six months and came to a close in June 2013.

NDEMC launched in July 2011, initially focusing its efforts in the manufacturing-heavy U.S. Midwest—in a pilot program called the NDEMC-Midwest Project. The project’s private sector investing partners were Procter & Gamble, General Electric Company, Deere & Company,

and the Lockheed Martin Corporation. These investors contributed approximately \$2 million, matched by the U.S. Department of Commerce Economic Development Administration. The State of Ohio also contributed, making the NDEMC–Midwest in total a \$4.9 million pilot project.

NDEMC’s industry and university partners were asked to recommend SMEs and their candidate projects for participation in the demonstration. SME projects were selected based on a number of criteria such as: (1) commitment level of a sponsor, including provision of engineering and technical support; (2) level of the SME’s interest in participating and willingness to engage in a range of project activities; (3) need or problem to be addressed with MS&A/HPC and the proposed solution; (4) potential for development of intellectual property; (5) the technical and labor resources required; and (6) the estimated impact on the SME in terms of new product development, reduced costs, expansion of its customer base, increased sales, and other benefits.

The Executive Board approved 20 demonstration projects over the course of NDEMC-Midwest.

## NDEMC MS&A/HPC Training

The NDEMC team developed educational curricula based on existing training software and materials developed by independent software vendors whose MS&A software was used in the pilot project

- **Education videos on MS&A/HPC** Eight education and training videos for SMEs were developed by the National Center for Manufacturing Sciences (NCMS). The videos cover the value, requirements, ROI and adoption of MS&A/HPC tools.
- **Two-day NCSA MS&A/HPC training program** After on-site visits to SMEs, NCSA designed an M&S workshop to address the SMEs specific needs. Training sessions introduced state-of-the-art simulation tools and HPC practices to SMEs with

no or moderate existing M&S capability, providing them the opportunity to assess first-hand M&S’s potential impact on design cycle times and overall competitiveness. The SMEs were also introduced to theoretical M&S concepts and fundamentals, with applied examples. The training workshop was conducted using lectures and interactive hands-on laboratory sessions taught by the NCSA team, and one-on-one discussion sessions. Technologies covered included Finite Element Analysis (FEA), High Performance Computing (HPC), and Computational Fluid Dynamics (CFD). Software covered included Simulia ABAQUS FEA, ANSYS FLUENT, CD-adaptco STAR-CCM+.



*Dr. Thomas Peterson, Assistant Director of Engineering, National Science Foundation; Dr. Phillip Singerman, Assistant Director for Innovation and Industry Services, National Institute of Standards and Technology, The Honorable Aneesh Chopra former U. S Chief Technology Officer; The Honorable Ron A. Bloom, former Assistant to the President for Manufacturing Policy, the White House; the Honorable John R. Fernandez, former Assistant Secretary, Economic Development Administration, the Honorable Dr. Steven Koonin, former Under Secretary for Science, Founding Director, Center for Urban Science and Progress, Leonard N. Stern School of Business, New York University; Dr. Robert (Bobby) Braun, former Chief Technologist, National Aeronautical and Space Administration.*



*The Honorable Aneesh Chopra, former U.S. Chief Technology Officer; Dr. George B. Adams III, former Director, ManufacturingHUB.org, Purdue University; Mr. Lary Rosenboom, Founder and President, Rosenboom Machine & Tool, Inc.; the Honorable John Fernandez, former Assistant Secretary, Economic Development Association (EDA), U.S. Department of Commerce and Dr. Klaus Hoehn, Vice President, Advanced Technology and Engineering, Deere & Co. appear on a panel session during the Council's Manufacturing Summit in December 2011 in Washington, DC.*

*In 2012 at the SC12 Supercomputing Conference in Salt Lake City, HPCwire, a reliable source for advanced computing news coverage, honored NDEMC for its role in facilitating HPC resources to small and medium-sized manufacturing enterprises (SMEs).*



**Front row:** Dave Hudak, Program Director for Cyber Infrastructure and Software Development, Ohio Supercomputer Center; Thom Dunning, NCSA Director; Tom Tabor, CEO and Founder Tabor Communications; Cynthia R. McIntyre, Senior Vice President, Council on Competitiveness; Aaron Malofsky, Program Manager, Council on Competitiveness; and Ashok K. Krishnamurthy, former Interim Co-Executive Director, Ohio Supercomputer Center.

**Back row:** Mr. Merle Giles, Director, Private Sector Program and Economic Development, The National Center for Supercomputing Applications (NCSA), the University of Illinois at Urbana-Champaign; Mr. Tom Lange, Director, Modeling & Simulation, Corporate R&D, Procter & Gamble; Dr. George B. Adams III, former Director, ManufacturingHUB.org, Purdue University; Mr. Dennis Thompson, Technical Project Manager, NDEMC and Senior Vice President, SCRA; Mr. Dwayne Sattler, Associate Vice President for Policy, Ohio Technology Consortium, Office of Research, The Ohio State University; Mr. David Martin, Industrial Outreach Lead, Argonne National Laboratory; Dr. Alan Chalker, Program Director of CSE Research Applications, Ohio Supercomputer Center; and Mr. Darin Rosenboom, Engineer, Rosenboom Machine & Tool.

SME	Sponsor	Project	Location
GreenlightOptics	Lockheed Marting Corporation	Thermal Modeling	OH
Jeco Plastics	Purdue	Structural Finite Element Analysis (FEA)	IN
Plastipak Packaging Inc.	P&G	FEA Analysis	OH
Pratt Industries	P&G	Computational Fluid Dynamics (CFD) Using Mold Flow	OH
Adams Thermal	Deere & Co.	CFD/FEA, and Fatigue Analysis	IL
Rosenboom Machine & Tool	Deere & Co.	FEA and CFD	IA
TPI Composites	GE-Energy	FEA/Mold Flow	IA
Midwest Precision	Lockheed Martin	Hydraulic Actuator System	OH
Technology Management, Inc.	Lockheed Martin	Thermal Flow	OH
Applied Science, Inc.	Lockheed Martin	Process and Tool Development	OH
Quality Manufacturing Corporation	Deere & Co.	Structural Simulation/Product Design	IA
Modern Tool	Deere & Co.	Structural Analysis	MN
Replex Plastic, Inc.	OSC	M&S Mirror-Based Augmentation System	OH
AltaSim Technologies	OSC	Thermal Energy Management	OH
KLW	Kinetic Vision/OSC	Material Response	OH
Boss Industries	Purdue	Two-phase CFD Analysis	IN
Dekker Vacuum Technologies	Purdue	Liquid Ring Pump Optimization Phases 1 and 2	IN
Morrison Industries	NASA	Noise Reduction on Blower Fan	OH
MED Institute, Inc.	Purdue	Reduce Product Development Time	IN
Engendren, Inc.	OSC	Enhance Heat Exchanger Performance/Reliability	OH

# NDEMC Partner Spotlight

The Ohio Supercomputer Center (OSC) developed a web-based app (screenshot below) that simulates the process of filling a container with fluid. P&G provided problem-specific code that uses ESI's OpenFOAM modeling and simulation software to analyze a cylindrical tank being filled with water from two inlets at different speeds as air escapes from an outlet (some of the resulting visualizations are pictured at the bottom of this page).

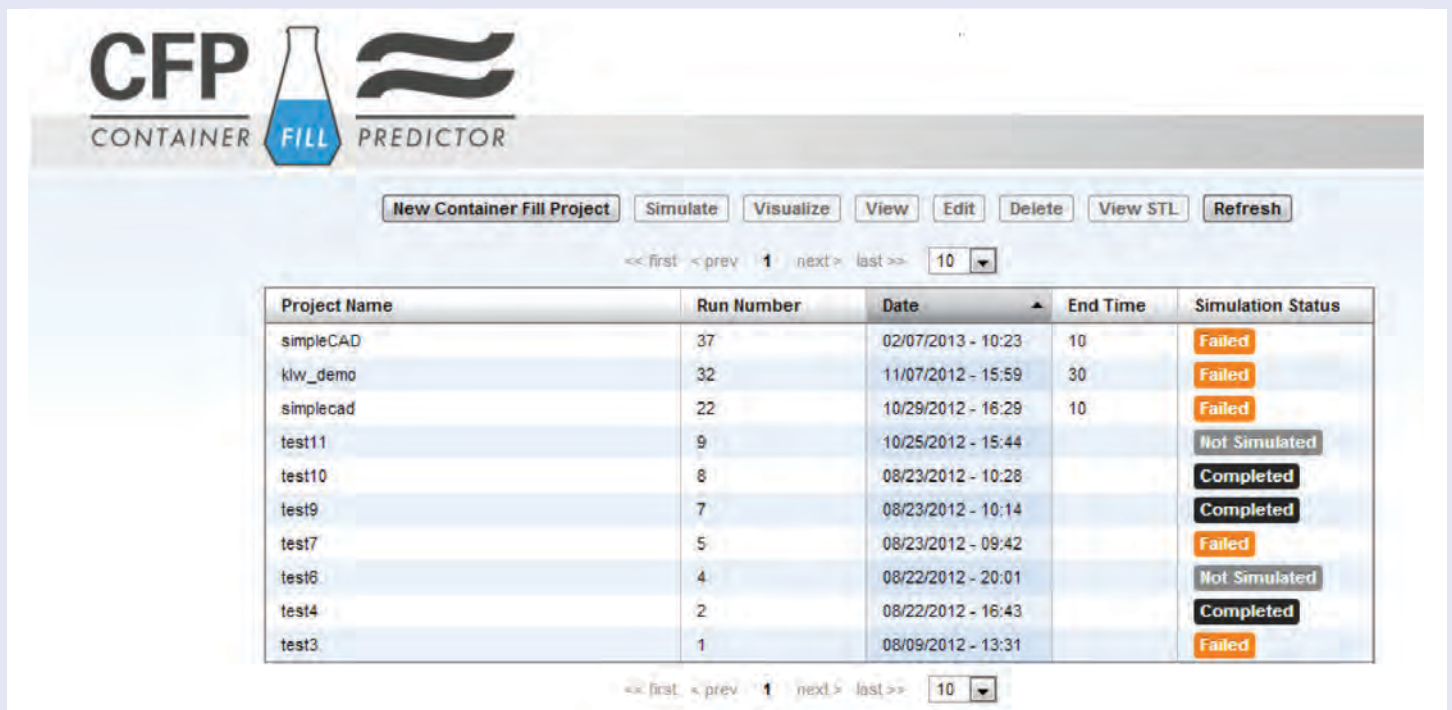

Project Name	Run Number	Date	End Time	Simulation Status
simpleCAD	37	02/07/2013 - 10:23	10	Failed
klw_demo	32	11/07/2012 - 15:59	30	Failed
simplecad	22	10/29/2012 - 16:29	10	Failed
test11	9	10/25/2012 - 15:44		Not Simulated
test10	8	08/23/2012 - 10:28		Completed
test9	7	08/23/2012 - 10:14		Completed
test7	5	08/23/2012 - 09:42		Failed
test6	4	08/22/2012 - 20:01		Not Simulated
test4	2	08/22/2012 - 16:43		Completed
test3	1	08/09/2012 - 13:31		Failed

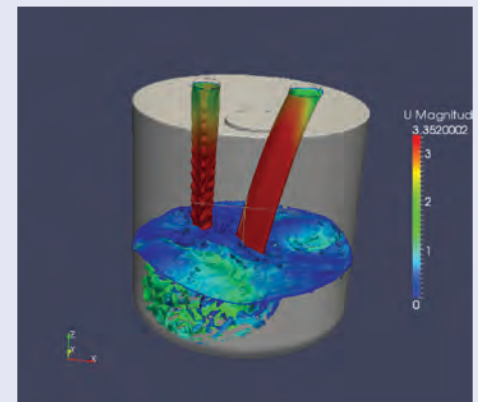
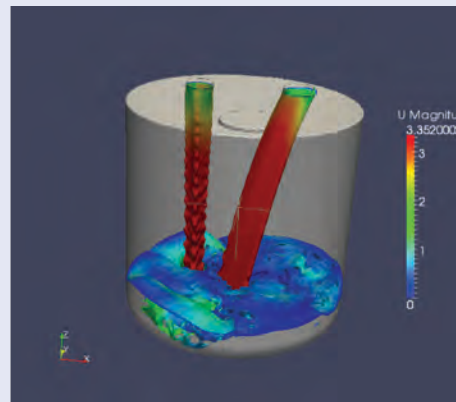
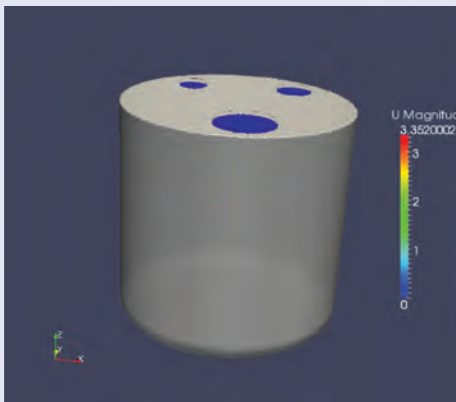

These projects reflect America's industrial diversity. They involved the use of MS&A/HPC in the development and/or improvement of products ranging from plastic pallets, components for air compressors, and vacuum pump equipment to engine cooling systems, containers, fuel cells, weld joints, and molds for precision plastic optics. Projects were guided by detailed project plans developed by participants that described what was to be accom-

plished, the technical and functional requirements needed to accomplish project goals, business case metrics, project costs, reporting mechanisms, and project timeline.

During the course of NDEMC-Midwest, demonstration project participants had multiple meetings, conference calls, and workshops.

Four projects were not completed. In two cases, opera-



Flowchart for NDEMC Demonstration Portal.

tions personnel convinced corporate management that their workload prohibited taking on the project at that time. People on the factory floor will not accept the type of help NDEMC provides if their business leadership does not communicate their support for MS&A. In the other two cases, the management team did not see the need or benefit of using MS&A even after meeting with their OEM customers (sponsors of the potential projects) who explained the long term benefit and return on investment. Some SMEs have not built cultures of continuous innovation that might be essential to the long-term survival of their business.

### **Need for On-Board Expertise and Consultation with SMEs**

Although NDEMC had originally envisioned the use of field trainers, as the project evolved and SMEs were engaged, a need for “subject matter experts/trainers” was identified. The SMEs needed education on what is possible and a subject matter expert to work with them to help analyze problems, determine best approaches, and to choose the best software tools to solve a problem. As a result, four subject matter experts/trainers were hired that acted as consultants, providing the SMEs on-site consulting and project support.

### **NDEMC Software Development**

In the course of carrying out the NDEMC demonstration projects, a number of software applications (APPs) were created. These APPs were developed as add-ons to open source, proprietary software or commercial software to solve a specific problem. Needed information is loaded into an APP’s template and, once the APP is launched, it uses the background software to solve the problem. Two APPs that were used and re-used are Weld Predictor and Manifold Flow Predictor. For example, Weld Predictor built by GE and OSC gives a weld engineer and the welder a tool for developing a weld pattern to meet the designer’s requirements. Manifold Flow Predictor was contributed by the Procter & Gamble Company. These APPs are available on the NDEMC/Nimbis Prototype Portal.

# NDEMC A Win–Win Partnership

All NDEMC partners gained business advantage from their participation in the Midwest Pilot.

- While not expecting a “return on investment” in traditional accounting terms, the OEMs gained significant non-financial returns on the time and effort they devoted to NDEMC. These include strengthening the SME supply chain community on which OEMs depend, and connecting SMEs with higher education institutions and the resources of Argonne National Laboratory and NASA. For OEMs, the Midwest Pilot was a stepping stone toward a MS&A-savvy supply chain that lowers cost, raises quality, and encourages cultures of continual innovation.
- Solution partners obtained greater insight on the challenges of deploying MS&A/HPC to SMEs, and were able to advance and gain experience with the outreach and technical models they have been employing. They are moving ahead on their own to further the NDEMC program.
- For the National Center for Supercomputer Applications (NCSA), NDEMC provided an opportunity to collaborate with government agencies, peer academic non-profit institutions, and a broad set of SMEs.
- For the Ohio Supercomputer Center (OSC), NDEMC was critical in moving OSC from case-by-case engagements with their Blue Collar Computing program, to a tested model for building simulation infrastructure. This progress has attracted significant funding to take the next step towards a sustainable business of engaging SMEs in Ohio and beyond with MS&A.
- Through participation in NDEMC, Purdue University got the opportunity to use the Indiana Manufacturing Extension Partnership Center it operates to engage SMEs outside an OEM supply chain, to partner with NCSA and OSC in solving SME innovation challenges, and to use its HUBzero™ software platform to deliver focused simulation Apps to SMEs that they are able to use themselves.
- Government partners reported that NDEMC exceeded their expectations by: demonstrating that advanced technology could be transferred effectively to a diverse set of SMEs; showcasing the value of cloud-based software-as-a-service offerings; and, for one federal agency, capturing returns as the SMEs used software the agency had developed that was “sitting on the shelf.”

## Manifold Flow Predictor (MFP) APP

Manifold Flow Predictor (MFP) is a computational fluid dynamics (CFD) tool designed to simulate the behavior of fluids flowing through a manifold, a pipe or chamber that branches into several openings. MFP helps engineers gain insight into how changes in either the manifold or the fluid affect the flow. MFP helps answer questions such as “how much injection pressure is required to ensure a given output?”

Using a web browser interface, MFP users upload CAD files describing the manifold, and input six parameters to specify the CFD simulation. Using both proprietary and open software systems, MFP launches a simulation

run in one of a set of computational cloud resources. Middleware monitors the run to ensure it is completed, restarting it and/or migrating it to another cloud resource as needed. Then the middleware delivers the results as an interactive display in the user’s browser window. The user may revise the simulation parameters, make a new run, and the new results will be displayed with the earlier results directly in the same browser window for easy comparison.

MFP is hosted at [ManufacturingHUB.org](http://ManufacturingHUB.org) and can be accessed with any modern web browser after logging in to this web site.

# Economic Impact of the NDEMC

Projects that were completed in the first phase of the pilot program created more than 160 new jobs in 2012, and increased sales by more than \$20 million/year, with half of that an increase in exports. In addition, the SMEs developed three new products. The SME that developed one of these is applying for a patent, and has made capital investments of about \$600,000 to advance the new product toward the marketplace. These numbers will increase as more of the demonstration projects are fully implemented.

Using the group of SMEs that participated in the demonstration as a microcosm of the more than 250,000 smaller manufacturers in the United States, if NDEMC was expanded, to apply its model to 1,000 SMEs, it would be reasonable to expect those engagements would result in 150 new products; 50 new patent applications; \$1 billion in new sales, with half in exports; and 8,000 new hires.



*The Honorable Matthew Erskine, Deputy Assistant Secretary, Economic Development Administration (EDA), U.S. Department of Commerce and Dr. Ashok Krishnamurthy, former Interim Co- Executive Director & Senior Director of Research, Ohio Supercomputer Center, give a presentation on the new HPC system dedicated to the NDEMC Midwest Project under the EDA Award.*

## Examples of Economic Impact from NDEMC Demonstration Projects

### Jeco Plastic Products, LLC

- \$2.5 million/year in increased sales
- 15 new hires
- New intellectual property and products developed (potential annual sales of \$10 million/year)

### Dekker Vacuum Technologies

- \$2-5 million/year in increased sales
- Created a new product with \$3-5 million/year sales
- 8 new hires

### Rosenboom Machine & Tool

- \$7 million/year in increased export sales
- 150 new hires

### GreenLight Optics

- Stopped plan to offshore work to China
- \$100,000 in new sales
- 1 new hire

# Findings and Lessons Learned

The NDEMC partners and SMEs involved in projects concluded that the NDEMC-Midwest pilot project was a very successful “proof of concept.” The NDEMC model has significant potential for making U.S. SMEs more competitive globally through the use of MS&A/HPC. The pilot project demonstrated that when SMEs have access to MS&A/HPC (see Appendix C), they are able to create and improve products and processes that make them more competitive and expand their business.

NDEMC has developed a powerful brand. Publicity about NDEMC’s first SME projects reached federal agencies, non-profit organizations and for-profit businesses widely. The launch of the Federal Advanced Manufacturing Partnership and National Network for Manufacturing Innovation initiatives further highlighted the early work of NDEMC, and grew mindshare for the NDEMC mission. In recognition of the pilot program’s success:

- HPCwire news report named NDEMC as “Best HPC Collaboration between Government and Industry;”
- Dr. Cynthia R. McIntyre was named by HPCwire as one of the 2013 People to Watch
- The NDEMC partners identified “lessons learned” that should guide future NDEMC efforts and help ensure their success

Events where the Council on Competitiveness highlighted the lessons learned include:

- 1) Council on Competitiveness U.S. Manufacturing Competitiveness Summit 2011
- 2) Supercomputing 2012 NDEMC Panel
- 3) Supercomputing 2013 NDEMC Presentation during Exhibit Showcase
- 4) Dr. McIntyre Invited Panelist for International Supercomputing Conference 2013

## Findings and Lessons Learned: The NDEMC Model, and the Value of Public-Private Partnerships

**Public-private partnerships are an essential model for undertaking complex projects, where new infrastructure or “industrial commons” need to be developed to support an entire industry sector.**

No single organization has the financial and technical resources, expertise and know-how, networks, and connections with government, businesses, and universities to establish a new national capacity to deploy advanced technologies and make them widely accessible in the United States. The OEM partners value the way these partnerships provide rallying points that stimulate mutually beneficial collaboration and community formation that likely would not occur otherwise, despite the mutual interests. Each of the non-SME NDEMC partners contributed resources to the project, and it was noted that this “ownership” of the project made for better engagement and cooperation. However, the lack of contractual arrangements among the partners was noted as a negative.

OEMs, independent software providers, and solution partners view NDEMC as addressing a well-defined SME community need, but for which there was no prior experience or existing models on how to address that need. For this reason, NDEMC took advantage of its partner diversity to test several ideas for delivering HPC and MS&A software and several approaches to engaging SME participants. Some of these approaches worked well, some were a struggle, and some failed. As NDEMC explored the reasons driving success, struggle, and failure, the mix of outcomes resulted in learning more about how to support SME innovation and competitiveness.

One OEM indicated that NDEMC—with its four OEMs, four solution partners, Argonne National Laboratory, NASA Glenn, and Nimbis Services, Inc., and with its level of government support—is about the minimum size of a community needed to attract independent software ven-



#### *NDEMC Portal Planning Meeting*

*Front row:* Thomas Bitterman, Senior Software Engineer, Ohio Supercomputer Center (OSC); Matt Sakey, Global Brand Manager, National Center for Manufacturing Sciences (NCMS); Paul Domagala, Lead Systems & Network Administrator, Argonne National Laboratory (ANL); Brian Schott, Chief Technology Officer, Nimbis Services, Inc.; and Dave Hudak, Director of Supercomputer Services, OSC.

*Back row:* Dennis Thompson, Senior Vice President, SCRA Applied R&D; Merle Giles, Director, National Center for Supercomputing Applications (NCSA); Steven Hale, Senior Program Manager, NCMS; George Adams, Director, ManufacturingHUB.org; Bob Graybill, President and CEO, Nimbis Services, Inc.; Ashok Krishnamurthy, Interim Co-Executive Director, OSC; Jon Riley, Vice President, Digital Manufacturing, NCMS; and Alan Chalker, Program Director of CSE Research Applications, OSC.

dors, engage an ample cohort of SMEs, and encourage them to try a new business model. A larger partnership may provide a more compelling value proposition to those considering engagement because more will be learned, more quickly. However, it was noted that larger partnerships could be difficult to govern and manage.

The total number of persons and organizations touched by NDEMC and all of its SME projects, the diversity of organizational cultures, the number of business domains represented, and the range of technical disciplines addressed gave NDEMC a character typically found only in a far larger entity. Over the period of the NDEMC Midwest Pilot, NDEMC became a partner in the National Additive Manufacturing Institute based in Youngstown, OH.

**NDEMC's solution partners found the partnership model to be a valuable learning mechanism, and effective in demonstrating MS&A/HPC technology to SMEs.** The NDEMC project helped these solution partners learn about the degree of simulation taking place across the participating OEMs' supply chains, and to identify issues and potential solutions to the questions that surround deployment of MS&A/HPC to SMEs. Working to bring MS&A/HPC resources to SMEs allowed the solution partners to explore the so-called "Missing Middle" market gap, and gauge the SME market demand for MS&A/HPC in various forms. Conversely, NDEMC demonstrated the value of connecting SMEs to the NDEMC's academic computing partners for collaborations with their faculty and students, and use of their MS&A tools.

**The NDEMC partnership reduced risks for both SMEs and OEMs.** For OEMs participating in the project, working digitally with their suppliers, which some had not done before, reduced risk. For example, Jeco Plastic Products needed to solve a technical challenge on a potential customer's very tight schedule. Jeco CEO Craig Carson was able to meet a faculty expert in finite element analysis, describe his problem, and listen to the expert's credible, unbiased advice about MS&A and how to best use NDEMC resources to meet the customer's quality and timeline requirements—"a critical connection to make at a very important time" said Carson.

**More planning is required.** NDEMC leadership needed greater planning to understand all costs associated with each SME project (e.g., there is a need for increased research validation testing).

**A robust, "industrial strength" portal/marketplace is required to operate the NDEMC model efficiently and successfully.**

## **SME Participation in NDEMC and MS&A/HPC Projects**

**SMEs cannot justify and are unwilling to purchase expensive MS&A/HPC tools, but will buy access.**

Due to the smaller size of their business, smaller product portfolios and sales compared to their large global counterparts, SMEs' ability to use these expensive tools is more limited and purchasing them is unlikely to generate an adequate return on investment. However, recognizing the potential for enhancing their ability to innovate, and increasing their productivity and profitability, SMEs are willing to buy access to MS&A/HPC, consulting, and training on a pay-by-the-use model. This points to the need for widespread access to shared MS&A/HPC infrastructure in the United States.

**The Software-as-a-Service (SaaS) Business Model could expand SME use of MS&A/HPC tools.** As it is emerging in the broader markets for IT services, Independent MS&A/HPC Software Vendors (ISVs) are slowly coming to the new model of Software-as-a-Service (SaaS). If this trend continues and is encouraged, it could accelerate the establishment of wider access to MS&A/HPC tools for U.S. SMEs. Further work to engage ISVs to test new business models welcomed by SMEs would be valuable.

However, commercial software models that work at OEMs need to be retooled for SaaS. For intermittent use of simulation, approaches could include very focused Apps with a small set of inputs to minimize the user learning curve, or a general-purpose simulation engine with bleeding-edge ease-of-use and artificial intelligence to keep the user on track to a meaningful solution. The ISVs are working on their own SaaS portals, as well as collaborating with others that are building portals, but it is still early in the development of portal SaaS.

**The opportunity to "reduce time-to-market for products" is an important factor in SMEs' decision to participate in NDEMC.**

**Computational resources that have a steep learning curve will not be useful.** The time horizon is often very short, for SMEs to seize an opportunity or solve a problem.

**Senior management, engineering, and operations personnel need to "buy-in" to projects to help ensure their success.** Defining clear project goals and expected outcomes, and conveying them from the top down is critical. The time and effort required to engage in an MS&A/HPC project must be transparent and stipulated upfront to SME operations personnel and to corporate management. A strong business case for participating in a project must be developed and presented to company management, illuminating how MS&A/HPC can meet important business needs, and the long-term return on investment that could be achieved. However, solution providers noted that it frequently takes time before the magnitude of the return on investment from SME engagement in a public-private partnership can be determined.

**SMEs need significant hands-on support and training to realize fully the potential of incorporating MS&A/HPC resources into their business operations.** There were astounding technical challenges in addressing the SMEs' simulation needs. Small companies have very challenging engineering design and manufacturing problems. The public-private partnership model is more suited to training SMEs than independent software vendors or OEMs. SMEs need a neutral and trusted third party to help educate them on MS&A/HPC, and provide ongoing guidance and support to assist them in developing solutions they can apply in their business.



*Dr. Cynthia McIntyre, Senior Vice President, Council on Competitiveness, testifies before Congress, on July 9th, 2013, for the hearing on American Competitiveness Worldwide: Impacts on Small Businesses and Entrepreneurs. She discussed the benefits of MS&A resources on the participating SMEs involved in the NDEMC program.*



*Dr. Robert Easter, President, University of Illinois and Dr. Phyllis Wise, Chancellor, University of Illinois at Urbana-Champaign, attend the White House Announcement of the Digital Manufacturing and Design Innovation (DMDI) hub and awardees, February 25, 2014.*

## Role of Government Partners

**Federal funding agencies could play a greater role in day-to-day oversight of the public-private partnership.** The National Network of Manufacturing Innovation (NNMI) centers are being designed with a dedicated point of contact from the primary funding agency. The difference between an agency grant model and an agency-funded partnership is that the agency has a seat at the table in the management and day-to-day operation of the partnership, which it does not for a grant.

**Greater flexibility in federal budget rules would enhance the ability of groundbreaking partnerships to achieve their goals.** With a relatively fixed federal budget and strict rules on the allowable sources of funds for portions of the NDEMC project, pivoting to respond to what was being learned from failures and struggles, and to offer new business models to the SMEs to address these challenges, was made difficult.

**The Manufacturing Extension Partnership could play a greater role in NDEMC.** The MEP centers are on the “front-line” in working with SMEs to deploy and use advanced technologies in their operations. The centers would be natural partners to help more American manufacturers gain the competitive edge conferred by MS&A/HPC.

# Next Steps and Future of NDEMC Initiatives

The Council and NDEMC's investing OEM partners plan to expand NDEMC's activities to other parts of the country. The vision is for NDEMC to evolve over five years from the "proof of concept" pilot project to a self-sustaining, national network continuing its mission independent of federal government support. Building on the knowledge and experience generated in the NDEMC pilot program, participants estimate that NDEMC needs three to five years to build out the model, a robust marketplace portal, and to develop and execute a business plan to create a self-sustaining enterprise. With this vision in mind, and having successfully completed the pilot phase demonstrating its value, the Council incorporated NDEMC Inc. as a 501(c)(3) business organization and seeks to raise fund to continue to develop and expand NDEMC.

NDEMC solution partner, Ohio Supercomputer Center, was awarded in 2013 a grant from The Ohio Third Frontier to enhance support of Ohio SMEs as a result of the NDEMC success.

On February 25, 2014 the White House announced that the University of Illinois System's UI Labs won the U.S. Department of Defense Digital Manufacturing and Design Innovation Grant. NDEMC is a supporting organization of the Award. The Award is part of a \$320 million total contribution to create a Digital Lab for Manufacturing. The Digital Lab for Manufacturing addresses the life cycle of digital data interchanged among design, engineering, manufacturing, and maintenance systems—including across a networked supply chain.

OEMs see next steps as clearly justified by NDEMC successes. NDEMC's core mission to address the "missing middle" by making MS&A/HPC accessible to SMEs is widely viewed as a key strategy for the future U.S. economic security, and the foundation on which to build is strong.

However, there are significant challenges in scaling up to deliver MS&A/HPC resources to more than a handful of companies simultaneously. There is consensus among the NDEMC partners that experimentation will be necessary. The Agriculture Extension model—engaging clients locally, serving as a neutral third-party technical resource, and bringing problems from clients to researchers—was cited as a proven success for one sector of the economy that could be adapted to the advanced manufacturing sector.

Participants discussed several expansion strategies - some focused on particular regions or industries, and others focused on similar classes of simulation problems or discrete industrial products and parts. Potential industry targets, for example, could be those that are heavy users of computer-aided engineering tools.

With both profit and non-profit options for expansion, NDEMC could become a neutral third party broker of independent software vendor and engineering services, serving as a respected brand and clearinghouse, and collecting fees for its assistance. SMEs could be supported for any number of uses of MS&A resources.

The App concept used with some NDEMC SMEs is of interest to the independent software vendor partners. They see the potential value of an App ecosystem for advanced manufacturing.

Also, NDEMC is in discussions with the Manufacturers Association of Florida to use NDEMC as the technical infrastructure for a center the Association is developing with funding from the state of Florida.

The Appendix includes the Memorandum of Understanding from March 2, 2011.

# Acknowledgements

The Council and NDEMC recognize the following individuals. This project would not have been possible without their leadership, dedication, hard work and expertise.

*Special recognition is given to Dr. Cynthia McIntyre, Senior Vice President, Council on Competitiveness, who lead this project from the beginning of advocacy in 2009 to completion in 2013. The Council and NDEMC commend her commitment to U.S. innovation, and America's SMEs and their competitiveness.*

The Honorable Ron Bloom  
White House, Office of Manufacturing Policy

The Honorable Deborah  
L. Wince-Smith  
Council on Competitiveness

William Booher  
Council on Competitiveness

The Honorable John Fernandez  
Economic Development Administration

The Honorable Thomas Guevara  
Economic Development Administration

The Honorable Matthew Erskine  
Economic Development Administration

The Honorable Aneesh Chopra  
White House, Office of Science &  
Technology Policy

Sridhar Kota  
White House, Office of Science &  
Technology Policy

The Honorable Sherrod Brown of Ohio

The Honorable Daniel Lipinski of Illinois

Thomas Lange  
The Procter & Gamble Company

Sean McClure  
U.S. Department of Treasury

Rob Neely  
Lawrence Livermore National Laboratory

Ed Morris  
Lockheed Martin

Alice Popescu-Gatlan  
Deere & Company

Bryan Dods  
General Electric Energy

William Flite  
Lockheed Martin

Dwayne Sattler  
Ohio Board of Regents

Donald Lamb  
University of Chicago

Merle Giles  
National Center for Supercomputing Applications

George Adams  
Purdue University

David McKinnis  
Purdue University

Alan Chalker  
Ohio Supercomputer Center

Ashok Krishnamurthy  
Ohio Supercomputer Center

Prakaj Shah  
Ohio Supercomputer Center

Jon Riley  
National Center for Manufacturing Sciences

Paul Domagala  
Argonne National Laboratory

Carol Tolbert  
NASA Glenn

Jack McDougle  
Council on Competitiveness

William Bates  
Council on Competitiveness

Dennis Thompson  
SCRA

Curtis Holcomb  
SCRA

Robert Graybill  
Nimbus Services, Inc.

Aaron Malofsky  
Council on Competitiveness

Steven McKnight  
National Science Foundation

Phillip Singerman  
National Institute of Standards and Technology

Jose Munoz  
National Science Foundation

Bruce Kramer  
National Science Foundation

Chad Evans  
Council on Competitiveness

Richard Arthur  
GE Global Research

Keven Hofstetter  
Caterpillar, Inc.

Paul Fussell  
Boeing

Steve Straub  
CD-adapco

Barbara Hutchings  
Shane Moeykens  
ANSYS, Inc.

Thomas Peterson  
National Science Foundation

Lawrence Summers  
White House, Council of Economic Advisors

Gene Sperling  
White House, Council of Economic Advisors

Jason Miller  
White House, Office of Manufacturing Policy

Dassault Systemes

# Appendix A

On March 2, 2011, the White House announced that the Council would lead and held a Memorandum of Understanding signing ceremony to create the first public-private partnership of the Obama administration focused on SME advanced manufacturing capability. Participating in the MOU signing ceremony representing the White House were Manufacturing Czar Ron Bloom, U.S. Chief Technology Officer Aneesh Chopra, U.S. Assistant Secretary for Economic Development John Fernandez, Deputy Assistant Secretary of Energy Steven Koonin, NASA Chief Technologist Robert Braun, NIST Associate Director Phillip Singerman and NSF Assistant Director Thomas Peterson. NDEMC was intended to operate as a pilot program for 18 months, as the first phase of a five-year effort. The demonstration phase of the program was extended for an additional six months and came to a close in June 2013.

## **Memorandum of Understanding**

### **Among:**

**The United States Government as represented by The National Economic Council/Office of Manufacturing Policy; Office of Science and Technology Policy; The Department Of Commerce; The National Aeronautics and Space Administration; The National Science Foundation; and the Department of Energy with; Deere & Company; General Electric Company; Lockheed Martin Corporation; The Procter & Gamble Company, Purdue University and the Ohio Board of Regents.**

### **Authorities**

The U.S. Government agencies participating in this Memorandum of Understanding (MOU) will be acting on their own authorities, as noted in the United States Code. These authorizations for the agencies, together with the internal policies and procedures of each, define the authority of these agencies to enter into this MOU and to facilitate the dissemination of certain technologies to improve the competitiveness of small and medium sized enterprises (SMEs).

### **Background:**

Recent advances in computer technology have made it possible to significantly reduce the length of time for a new product to be produced at a commercial scale. Traditionally, a number of physical models were built and tested prior to commercial production; however with computer-based modeling and simulation a product can be quickly tested numerous times before a physical model is needed. While this technology is currently being employed by larger companies, there appear to be opportunities to make the technology available to first- and second-tier suppliers, including small- and medium-sized enterprises (SMEs).

### **Purpose:**

The Obama Administration is committed to revitalizing our nation's manufacturing sector through, among other things, improving its competitiveness in the global economy. Toward that end, the President has designated an Assistant to the President for Manufacturing Policy and assigned that office the task of providing a greater level of coordination and focus on the Administration's many programs that support manufacturing.

This MOU shall evidence the agreement of the United States Government through its designated Departments and Agencies (National Economic Council (NEC)/Office of Manufacturing Policy; the Office of Science and Technology Policy (OSTP); the Department of Commerce, (Economic

Development Administration (EDA); and the National Institute of Standards and Technology (NIST); the National Aeronautics and Space Administration (NASA); the National Science Foundation (NSF); the Department of Energy (DOE)(collectively, USG), together with Deere & Company; General Electric Company; Lockheed Martin Corporation; Procter & Gamble Company; Purdue University and the Ohio Board of Regents (the Parties) to work together on a project (Project) to facilitate the dissemination of certain technologies to improve the competitiveness of SMEs.

The use of computer-based modeling and simulation (M&S) has the potential to play an important role in helping America's SMEs achieve global competitiveness and create new employment opportunities.

In addition to the Parties to this MOU, the Project would be focused on large companies who are currently using M&S technology in their own product development, have significant networks of domestic SME suppliers, and believe that making this technology available to those suppliers could enhance the competitiveness of both the suppliers and the larger companies. This Project will also support maintaining America's lead in the development of the hardware and related software application for modeling and simulation.

The large companies would contribute time and resources, as well as agree to work both with each other and their suppliers. The Parties would facilitate this cooperation and in certain cases may consider providing resources to support the effort.

**Shared Goals:**

- Enhancing the competitiveness of SME manufacturers through the utilization of technology, specifically computer-based modeling and simulation.
- Maintaining a technological edge in M&S through adoption of state-of-the-art research advances.
- Strengthening the capacity of SMEs to create, commercialize, and manage new innovation and new products to improve economic competitiveness.

The Parties contemplate that they will plan and implement projects of mutual interest through one or more mechanisms which support the overall goals of advancing American manufacturing's productivity through the use of computer-based modeling and simulation.

**Designated Points of Contact:**

Each Party has appointed a primary point-of-contact and liaison responsible for the management and development of the relationship between the parties. These liaisons are listed below:

**USG:**

NEC/OMP: Ron Bloom

OSTP: Aneesh Chopra

DOC/EDA: A/S John Fernandez

DOC/NIST: U/S Patrick Gallagher

DOE: U/S Steven Koonin

NASA: Dr. Robert Braun

NSF: Director Subra Suresh

**PRIVATE PARTNERS:**

Deere & Company: Vanessa Stiffler-Claus

General Electric Company: Christine Furstoss

Lockheed Martin Corporation: Dr. Ray O Johnson

The Procter & Gamble Company: Bruce Brown

Purdue University: Dr. David R. McKinnis

Ohio Board of Regents: Eric D. Fingerhut

**Effective Date, Duration, Amendments, and Termination**

This MOU is strictly for internal management purposes for each of the Parties. It is not legally enforceable and shall not be construed to create any legal obligation on the part of the Parties. This MOU shall not be construed to provide a private right or cause of action for or by any person or entity.

The Parties agree that this MOU is not in any way an obligation of funds, nor does it constitute a legally binding commitment by any Party or create any rights for any Party regarding any project. Nothing in this MOU shall be interpreted as limiting, superseding, or otherwise affecting a Party from conducting normal operations or making decisions in carrying out its statutory or regulatory duties. This MOU does not limit or restrict the Parties from participating in similar activities or arrangements with other entities.

The Parties will, in all respects, continue to maintain their own separate and unique missions, mandates and statutory authorities as well as their own budgetary accountability. Each Party shall accept full and primary responsibility for any and all expenses incurred by that Party relating to this MOU. No Party will be responsible for any expense incurred by the other Parties unless specifically agreed to in writing.

Activities under this MOU shall commence upon the date of the last signature of all the Parties and are expected to continue for 5 years from that date. The Parties may decide to extend this period and/or add additional federal entities to this MOU. In addition, this MOU may be modified if all the Parties agree. Any party may terminate this MOU at any time, but will endeavor to provide 30 days written notice to the other Parties.

**Resolution of Disagreements**

Should disagreement arise under this MOU, or amendments and/or revisions thereto, that cannot be resolved at the division director level, the area(s) of disagreement shall be stated in writing by each Party and presented to the other Party at the assistant director or equivalent level for consideration.

 03-02-11  
 Ron A Bloom Date  
 Assistant to the President for Manufacturing Policy  
 National Economic Council, Manufacturing Policy

 3/2/11  
 Dr. Ray O Johnson Date  
 Senior Vice President and Chief Technology Officer  
 Lockheed Martin Corporation

 3/2/11  
 Aneesh Chopra Date  
 Assistant to the President, Associate Director  
 Office of Science and Technology Policy

 3/2/11  
 Vanessa Stiffler-Claus Date  
 Director of International Affairs  
 Deere & Company

 3/2/2011  
 Assistant Secretary John Fernandez Date  
 Economic Development Administration  
 Department of Commerce;

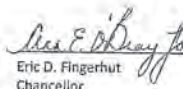
 3/2/11  
 Eric D. Fingerhut Date  
 Chancellor  
 Ohio Board of Regents

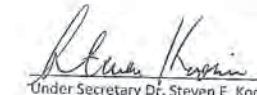
 3/2/11  
 Under Secretary Dr. Steven E. Koonin Date  
 Department of Energy

 02 March 2011  
 Christine Furstoss Date  
 Global Technology Director for Advanced Manufacturing  
 General Electric Company

 3/2/11  
 Chief Technologist, Dr. Robert Braun Date  
 National Aeronautics and Space Administration

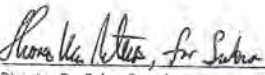
 3/2/2011  
 Director Dr. Subra Suresh Date  
 National Science Foundation

 3/2/11  
 Bruce Brown Date  
 Chief Technology Officer  
 The Procter & Gamble Company

 March 2, 2011  
 Dr. David R. McKinnis Date  
 Associate Vice Provost for Engagement  
 Purdue University

 2 March 2011  
 Under Secretary Patrick Gallagher Date  
 National Institute for Standards and Technology  
 Department of Commerce

  
 Eric D. Fingerhut Date  
 Chancellor  
 Ohio Board of Regents

# Appendix B

The Council produced a series of white papers informed by the HPC Manufacturing Working Group.

# U.S. Manufacturing— Global Leadership Through Modeling and Simulation

White Paper  
4 March 2009

**This is today's headline:** *The Collapse of Manufacturing*, and many U.S. manufacturers and their supply chains are in crisis. In this time of crisis, the U.S. has the technological tools to maintain our competitive edge and global leadership in manufacturing, but we risk our manufacturing leadership position if we fail to utilize the game-changing tool of high performance computing (HPC) for modeling, simulation, and analysis.

U.S. companies are responsible for producing a majority of the HPC systems appearing on the most recent list of Top 500 Supercomputer Sites.<sup>1</sup> The use of HPC has provided a competitive advantage for many of the manufacturing Fortune 50. These companies employ in-house advanced computing and have access to high performance computing hardware, software, and technical resources through partnerships with national laboratories and universities. For U.S. leading manufacturers, to out-compete is to out-compute. The U.S. Bureau of Economic Analysis indicates that manufacturing gross output has increased through 2007.<sup>2</sup> We must engage the tools and new technologies that have been the keys to our success.<sup>3</sup>

This transformative technology is used by international competitors of U.S. manufacturers, often through public-private partnerships some of which are cross-border. For example, HLRS, the German national high performance computing facility in Stuttgart, has assisted the nation's coal-fired power plant industry in using modeling and simulation to optimize plant design and operation. These simulations have led to reduced emissions, higher efficiency, greater boiler availability, and increased safety.<sup>4</sup> Meanwhile, the partnership between BMW and Japan's Earth Simulator supercomputer is benchmarking optimal automotive design, safety, and performance.<sup>5</sup>

U.S. national and economic security critically depend on our having innovative and agile manufacturing capabilities, and the current economic conditions have only heightened the need to accelerate competitive advantages for U.S. manufacturing companies.<sup>6</sup> Manufacturers can maintain their global leadership position only through technological differentiation, not through labor cost savings or other "old-world"<sup>7</sup> advantages. U.S. manufacturing is vital to the deployment of needed infrastructure, new energy sources, and transportation.

1 See <http://www.top500.org/>.

2 The U.S. Bureau of Economic Analysis (2008, December 15). *Gross Output by Industry*, at [http://www.bea.gov/industry/gpotables/gpo\\_action.cfm](http://www.bea.gov/industry/gpotables/gpo_action.cfm).

3 Barrett, Amy. (2009, February 13). US: Manufacturing at home. *BusinessWeek*, at [http://www.businessweek.com/smallbiz/content/feb2009/sb2009029\\_090545.htm](http://www.businessweek.com/smallbiz/content/feb2009/sb2009029_090545.htm).

4 Risio, B. PhD. (2008 October) *3-D Flame Modeling in Power Plant Applications* at <http://www.hpcuserforum.com/presentations/Germany/RECOM-3D-Flame-Modelling-HPC-User-Forum.pdf>.

5 Joseph, Earl (2005, January 27) *HPC User Forum, Earth Simulator Visit* [Meeting notes]. International Data Corporation.

6 Helper, Susan (2009). The High Road for U.S. Manufacturing. *Issues in Science and Technology* 25(2):39-45.

7 Palmisano, Sam (2009, February 19). Smart ways to prepare for a world beyond recession. *Financial Times*.

# U.S. Manufacturing— Global Leadership Through Modeling and Simulation

White Paper  
4 March 2009

**This is today's headline:** *The Collapse of Manufacturing*, and many U.S. manufacturers and their supply chains are in crisis. In this time of crisis, the U.S. has the technological tools to maintain our competitive edge and global leadership in manufacturing, but we risk our manufacturing leadership position if we fail to utilize the game-changing tool of high performance computing (HPC) for modeling, simulation, and analysis.

U.S. companies are responsible for producing a majority of the HPC systems appearing on the most recent list of Top 500 Supercomputer Sites.<sup>1</sup> The use of HPC has provided a competitive advantage for many of the manufacturing Fortune 50. These companies employ in-house advanced computing and have access to high performance computing hardware, software, and technical resources through partnerships with national laboratories and universities. For U.S. leading manufacturers, to out-compete is to out-compute. The U.S. Bureau of Economic Analysis indicates that manufacturing gross output has increased through 2007.<sup>2</sup> We must engage the tools and new technologies that have been the keys to our success.<sup>3</sup>

This transformative technology is used by international competitors of U.S. manufacturers, often through public-private partnerships some of which are cross-border. For example, HLRS, the German national high performance computing facility in Stuttgart, has assisted the nation's coal-fired power plant industry in using modeling and simulation to optimize plant design and operation. These simulations have led to reduced emissions, higher efficiency, greater boiler availability, and increased safety.<sup>4</sup> Meanwhile, the partnership between BMW and Japan's Earth Simulator supercomputer is benchmarking optimal automotive design, safety, and performance.<sup>5</sup>

U.S. national and economic security critically depend on our having innovative and agile manufacturing capabilities, and the current economic conditions have only heightened the need to accelerate competitive advantages for U.S. manufacturing companies.<sup>6</sup> Manufacturers can maintain their global leadership position only through technological differentiation, not through labor cost savings or other "old-world"<sup>7</sup> advantages. U.S. manufacturing is vital to the deployment of needed infrastructure, new energy sources, and transportation.

1 See <http://www.top500.org/>.

2 The U.S. Bureau of Economic Analysis (2008, December 15). *Gross Output by Industry*, at [http://www.bea.gov/industry/gpotables/gpo\\_action.cfm](http://www.bea.gov/industry/gpotables/gpo_action.cfm).

3 Barrett, Amy. (2009, February 13). US: Manufacturing at home. *BusinessWeek*, at [http://www.businessweek.com/smallbiz/content/feb2009/sb2009029\\_090545.htm](http://www.businessweek.com/smallbiz/content/feb2009/sb2009029_090545.htm).

4 Risio, B. PhD. (2008 October) *3-D Flame Modeling in Power Plant Applications* at <http://www.hpcuserforum.com/presentations/Germany/RECOM-3D-Flame-Modelling-HPC-User-Forum.pdf>.

5 Joseph, Earl (2005, January 27) *HPC User Forum, Earth Simulator Visit* [Meeting notes]. International Data Corporation.

6 Helper, Susan (2009). The High Road for U.S. Manufacturing. *Issues in Science and Technology* 25(2):39-45.

7 Palmisano, Sam (2009, February 19). Smart ways to prepare for a world beyond recession. *Financial Times*.

# U.S. Manufacturing— Global Leadership Through Modeling and Simulation

White Paper  
4 March 2009

**This is today's headline:** *The Collapse of Manufacturing*, and many U.S. manufacturers and their supply chains are in crisis. In this time of crisis, the U.S. has the technological tools to maintain our competitive edge and global leadership in manufacturing, but we risk our manufacturing leadership position if we fail to utilize the game-changing tool of high performance computing (HPC) for modeling, simulation, and analysis.

U.S. companies are responsible for producing a majority of the HPC systems appearing on the most recent list of Top 500 Supercomputer Sites.<sup>1</sup> The use of HPC has provided a competitive advantage for many of the manufacturing Fortune 50. These companies employ in-house advanced computing and have access to high performance computing hardware, software, and technical resources through partnerships with national laboratories and universities. For U.S. leading manufacturers, to out-compete is to out-compute. The U.S. Bureau of Economic Analysis indicates that manufacturing gross output has increased through 2007.<sup>2</sup> We must engage the tools and new technologies that have been the keys to our success.<sup>3</sup>

This transformative technology is used by international competitors of U.S. manufacturers, often through public-private partnerships some of which are cross-border. For example, HLRS, the German national high performance computing facility in Stuttgart, has assisted the nation's coal-fired power plant industry in using modeling and simulation to optimize plant design and operation. These simulations have led to reduced emissions, higher efficiency, greater boiler availability, and increased safety.<sup>4</sup> Meanwhile, the partnership between BMW and Japan's Earth Simulator supercomputer is benchmarking optimal automotive design, safety, and performance.<sup>5</sup>

U.S. national and economic security critically depend on our having innovative and agile manufacturing capabilities, and the current economic conditions have only heightened the need to accelerate competitive advantages for U.S. manufacturing companies.<sup>6</sup> Manufacturers can maintain their global leadership position only through technological differentiation, not through labor cost savings or other "old-world"<sup>7</sup> advantages. U.S. manufacturing is vital to the deployment of needed infrastructure, new energy sources, and transportation.

1 See <http://www.top500.org/>.

2 The U.S. Bureau of Economic Analysis (2008, December 15). *Gross Output by Industry*, at [http://www.bea.gov/industry/gpotables/gpo\\_action.cfm](http://www.bea.gov/industry/gpotables/gpo_action.cfm).

3 Barrett, Amy. (2009, February 13). US: Manufacturing at home. *BusinessWeek*, at [http://www.businessweek.com/smallbiz/content/feb2009/sb2009029\\_090545.htm](http://www.businessweek.com/smallbiz/content/feb2009/sb2009029_090545.htm).

4 Risio, B. PhD. (2008 October) *3-D Flame Modeling in Power Plant Applications* at <http://www.hpcuserforum.com/presentations/Germany/RECOM-3D-Flame-Modelling-HPC-User-Forum.pdf>.

5 Joseph, Earl (2005, January 27) *HPC User Forum, Earth Simulator Visit* [Meeting notes]. International Data Corporation.

6 Helper, Susan (2009). The High Road for U.S. Manufacturing. *Issues in Science and Technology* 25(2):39-45.

7 Palmisano, Sam (2009, February 19). Smart ways to prepare for a world beyond recession. *Financial Times*.

# U.S. Manufacturing— Global Leadership Through Modeling and Simulation

White Paper  
4 March 2009

**This is today's headline:** *The Collapse of Manufacturing*, and many U.S. manufacturers and their supply chains are in crisis. In this time of crisis, the U.S. has the technological tools to maintain our competitive edge and global leadership in manufacturing, but we risk our manufacturing leadership position if we fail to utilize the game-changing tool of high performance computing (HPC) for modeling, simulation, and analysis.

U.S. companies are responsible for producing a majority of the HPC systems appearing on the most recent list of Top 500 Supercomputer Sites.<sup>1</sup> The use of HPC has provided a competitive advantage for many of the manufacturing Fortune 50. These companies employ in-house advanced computing and have access to high performance computing hardware, software, and technical resources through partnerships with national laboratories and universities. For U.S. leading manufacturers, to out-compete is to out-compute. The U.S. Bureau of Economic Analysis indicates that manufacturing gross output has increased through 2007.<sup>2</sup> We must engage the tools and new technologies that have been the keys to our success.<sup>3</sup>

This transformative technology is used by international competitors of U.S. manufacturers, often through public-private partnerships some of which are cross-border. For example, HLRS, the German national high performance computing facility in Stuttgart, has assisted the nation's coal-fired power plant industry in using modeling and simulation to optimize plant design and operation. These simulations have led to reduced emissions, higher efficiency, greater boiler availability, and increased safety.<sup>4</sup> Meanwhile, the partnership between BMW and Japan's Earth Simulator supercomputer is benchmarking optimal automotive design, safety, and performance.<sup>5</sup>

U.S. national and economic security critically depend on our having innovative and agile manufacturing capabilities, and the current economic conditions have only heightened the need to accelerate competitive advantages for U.S. manufacturing companies.<sup>6</sup> Manufacturers can maintain their global leadership position only through technological differentiation, not through labor cost savings or other "old-world"<sup>7</sup> advantages. U.S. manufacturing is vital to the deployment of needed infrastructure, new energy sources, and transportation.

1 See <http://www.top500.org/>.

2 The U.S. Bureau of Economic Analysis (2008, December 15). *Gross Output by Industry*, at [http://www.bea.gov/industry/gpotables/gpo\\_action.cfm](http://www.bea.gov/industry/gpotables/gpo_action.cfm).

3 Barrett, Amy. (2009, February 13). US: Manufacturing at home. *BusinessWeek*, at [http://www.businessweek.com/smallbiz/content/feb2009/sb2009029\\_090545.htm](http://www.businessweek.com/smallbiz/content/feb2009/sb2009029_090545.htm).

4 Risio, B. PhD. (2008 October) *3-D Flame Modeling in Power Plant Applications* at <http://www.hpcuserforum.com/presentations/Germany/RECOM-3D-Flame-Modelling-HPC-User-Forum.pdf>.

5 Joseph, Earl (2005, January 27) *HPC User Forum, Earth Simulator Visit* [Meeting notes]. International Data Corporation.

6 Helper, Susan (2009). The High Road for U.S. Manufacturing. *Issues in Science and Technology* 25(2):39-45.

7 Palmisano, Sam (2009, February 19). Smart ways to prepare for a world beyond recession. *Financial Times*.

# High Performance Computing To Enable Next-Generation Manufacturing

White Paper  
16 January 2009

## HPC: The Real Game-Changer for U.S. Manufacturing

U.S. manufacturers are being challenged today by an unprecedented confluence of global events. This convergence of powerful internal and external forces—financial crisis, global economic contraction, an automotive manufacturing base at risk, and increasing competition from overseas—is challenging U.S. manufacturing leadership like never before. Indeed, these extraordinary circumstances require extraordinary measures, and the U.S. public and private sectors must cooperate strategically, coordinating and investing to repair, reposition, and reaffirm U.S. global leadership in manufacturing.

Research by the Council on Competitiveness presents powerful evidence of the capacity of high performance computing (HPC) to drive innovation and make U.S. companies and the nation more competitive. Indeed, for those who have adopted it, HPC represents a crucial edge that can build and sustain competitive advantage through innovative product design,<sup>i</sup> production techniques,<sup>ii</sup> cost savings,<sup>iii</sup> improved time-to-market cycles, and overall quality. However, Council research has also shown that many U.S. companies are “stuck at the desktop” and not able to take full advantage of HPC,<sup>iv</sup> while still others—including many suppliers to U.S. tier 1 companies—have limited, if any, computational R&D capacity (with many not even using desktop workstations).<sup>v</sup>

Our situation becomes even more critical when one surveys the competitive landscape that U.S. companies face today—where many foreign governments have established public-private partnerships for the use of HPC in manufacturing. Indeed, sustained national investments in innovation and manufacturing are occurring in China (e.g., China’s 863 Program<sup>vi</sup>), the European Union (PRACE program<sup>vii</sup>), and in the UK<sup>viii</sup> to name only a few. Meanwhile, our own national policy regarding HPC is fragmented.

The time is right for the U.S. federal government to take bold steps to leverage HPC for next-generation innovation, manufacturing, and U.S. competitiveness.

## A New Game-Changing Approach to Manufacturing

Incorporating support for HPC within the Obama-Biden stimulus plan for manufacturing would constitute a bold, but effective, first step. It would enable U.S. manufacturers to gain the edge they need to stay competitive globally, create new manufacturing jobs at home based on HPC-enabled innovations and breakthroughs, and have long-lasting derivative effects that could be beneficial for the overall economy.

# High Performance Computing To Enable Next-Generation Manufacturing

White Paper

16 January 2009

## HPC: The Real Game-Changer for U.S. Manufacturing

U.S. manufacturers are being challenged today by an unprecedented confluence of global events. This convergence of powerful internal and external forces—financial crisis, global economic contraction, an automotive manufacturing base at risk, and increasing competition from overseas—is challenging U.S. manufacturing leadership like never before. Indeed, these extraordinary circumstances require extraordinary measures, and the U.S. public and private sectors must cooperate strategically, coordinating and investing to repair, reposition, and reaffirm U.S. global leadership in manufacturing.

Research by the Council on Competitiveness presents powerful evidence of the capacity of high performance computing (HPC) to drive innovation and make U.S. companies and the nation more competitive. Indeed, for those who have adopted it, HPC represents a crucial edge that can build and sustain competitive advantage through innovative product design,<sup>i</sup> production techniques,<sup>ii</sup> cost savings,<sup>iii</sup> improved time-to-market cycles, and overall quality. However, Council research has also shown that many U.S. companies are “stuck at the desktop” and not able to take full advantage of HPC,<sup>iv</sup> while still others—including many suppliers to U.S. tier 1 companies—have limited, if any, computational R&D capacity (with many not even using desktop workstations).<sup>v</sup>

Our situation becomes even more critical when one surveys the competitive landscape that U.S. companies face today—where many foreign governments have established public-private partnerships for the use of HPC in manufacturing. Indeed, sustained national investments in innovation and manufacturing are occurring in China (e.g., China’s 863 Program<sup>vi</sup>), the European Union (PRACE program<sup>vii</sup>), and in the UK<sup>viii</sup> to name only a few. Meanwhile, our own national policy regarding HPC is fragmented.

The time is right for the U.S. federal government to take bold steps to leverage HPC for next-generation innovation, manufacturing, and U.S. competitiveness.

## A New Game-Changing Approach to Manufacturing

Incorporating support for HPC within the Obama-Biden stimulus plan for manufacturing would constitute a bold, but effective, first step. It would enable U.S. manufacturers to gain the edge they need to stay competitive globally, create new manufacturing jobs at home based on HPC-enabled innovations and breakthroughs, and have long-lasting derivative effects that could be beneficial for the overall economy.

# High Performance Computing To Enable Next-Generation Manufacturing

White Paper  
16 January 2009

## HPC: The Real Game-Changer for U.S. Manufacturing

U.S. manufacturers are being challenged today by an unprecedented confluence of global events. This convergence of powerful internal and external forces—financial crisis, global economic contraction, an automotive manufacturing base at risk, and increasing competition from overseas—is challenging U.S. manufacturing leadership like never before. Indeed, these extraordinary circumstances require extraordinary measures, and the U.S. public and private sectors must cooperate strategically, coordinating and investing to repair, reposition, and reaffirm U.S. global leadership in manufacturing.

Research by the Council on Competitiveness presents powerful evidence of the capacity of high performance computing (HPC) to drive innovation and make U.S. companies and the nation more competitive. Indeed, for those who have adopted it, HPC represents a crucial edge that can build and sustain competitive advantage through innovative product design,<sup>i</sup> production techniques,<sup>ii</sup> cost savings,<sup>iii</sup> improved time-to-market cycles, and overall quality. However, Council research has also shown that many U.S. companies are “stuck at the desktop” and not able to take full advantage of HPC,<sup>iv</sup> while still others—including many suppliers to U.S. tier 1 companies—have limited, if any, computational R&D capacity (with many not even using desktop workstations).<sup>v</sup>

Our situation becomes even more critical when one surveys the competitive landscape that U.S. companies face today—where many foreign governments have established public-private partnerships for the use of HPC in manufacturing. Indeed, sustained national investments in innovation and manufacturing are occurring in China (e.g., China’s 863 Program<sup>vi</sup>), the European Union (PRACE program<sup>vii</sup>), and in the UK<sup>viii</sup> to name only a few. Meanwhile, our own national policy regarding HPC is fragmented.

The time is right for the U.S. federal government to take bold steps to leverage HPC for next-generation innovation, manufacturing, and U.S. competitiveness.

## A New Game-Changing Approach to Manufacturing

Incorporating support for HPC within the Obama-Biden stimulus plan for manufacturing would constitute a bold, but effective, first step. It would enable U.S. manufacturers to gain the edge they need to stay competitive globally, create new manufacturing jobs at home based on HPC-enabled innovations and breakthroughs, and have long-lasting derivative effects that could be beneficial for the overall economy.

# High Performance Computing and U.S. Manufacturing Roundtable

White Paper  
25 February 2010

City View Room  
The George Washington University  
Elliott School of International Affairs  
1957 E Street, NW, 7th Floor  
Washington, DC

**Problem:** U.S. manufacturers must compete on innovation, not cost. High performance computing (HPC) modeling and simulation enables innovation by reducing design cycle time, development costs, certification costs, and re-engineering costs, and improving performance and efficiency while reducing waste.<sup>1</sup> Greater use of HPC modeling and simulation by U.S. manufacturers is therefore critical to creating and keeping good, high-paying jobs, strengthening and growing the U.S. manufacturing base and addressing the 21st century problems facing the U.S. and the world. Structural barriers and obstacles are preventing this from happening.

**Proposed Solution:** A public-private partnership between leading manufacturers and the federal government that would overcome/mitigate the structural barriers and obstacles to broader and deeper use of HPC modeling and simulation by U.S. manufacturers.

## Why Now?

- Proactive measures by the public and private sectors are needed to ensure U.S. manufacturers remain globally competitive.
- The only way to create and keep good, high-paying jobs and keep/grow the U.S. manufacturing base is for U.S. manufacturers to compete on innovation.
- HPC modeling and simulation are crucial to competing on innovation.

<sup>1</sup> "U.S. Manufacturing—Global leadership Through Modeling and Simulation," Council on Competitiveness draft white paper, 4 March 2009, p.3.

- DOE and DOD missions have put the United States ahead of most other countries in HPC modeling and simulation, but other countries realize its importance and are catching up.
- The United States must seize the advantage it has and exploit this advantage before the nation loses it.
- Yet the link between U.S. manufacturers and the HPC resources (hardware, software, and an educated and trained workforce) they need to exploit this advantage has stretched to the breaking point, if it has not actually snapped.

### **Why this workshop?**

- HPC modeling and simulation are used extensively by Fortune 50 manufacturers.
- However, structural barriers and obstacles exist to the Fortune 50 manufacturers fully exploiting HPC modeling and simulation, and even more to broadening their use to Fortune 200 manufacturers and deepening their use down the supply chains.
- Both are essential if the Fortune 200 manufacturers and their supply chains are to compete on innovation rather than cost—which is vital to growing/keeping good, high-paying jobs in the United States and strengthening the U.S. manufacturing base.
- The Fortune 50 manufacturers here today are stepping forward in the spirit of a “call to service,” and volunteering to form a partnership with the federal government to overcome/mitigate the barriers and obstacles to broadening and deepening the use of HPC modeling and simulation in U.S. manufacturing.
- The Council on Competitiveness’ HPC and Manufacturing working group will present the greatest barriers and obstacles, in its experience, to U.S. manufacturer’s innovation.
- The working group will put forth ideas and suggestions of how these barriers and obstacles could be overcome/mitigated, as a starting point for discussion.
- Finally, the working group will put before invitees some ideas/suggestions about what agencies and existing/future programs might contribute to overcoming/mitigating them, again as a starting point for discussion.

## **Topic A: Access to Hardware and Intellectual Capital for U.S. Manufacturers**

The federal government, through the national laboratory system, industry and academia, offer crucial computer hardware, scientific and engineering expertise, and research software in modeling and simulation to be deployed toward the goal. All of the nation's advanced computing resources (public and private) must be called upon, coordinated and leveraged for U.S. manufacturing competitiveness.<sup>2</sup>

**Problem:** U.S. manufacturing research centers lack high-speed Internet access to DOE and NSF leadership class computing facilities.

**Possible Solution:** A public-private partnership in which the federal government would extend the high-speed Internet backbone to underserved areas and leading manufacturers would underwrite the cost of high-speed Internet connections from their research centers to the backbone. Fortune 200 manufacturers would gain access to HPC resources through the establishment of advanced HPC service centers that would serve each of the 50 states for economic development (see below).

**Problem:** U.S. manufacturers need leadership-class computational resources, not only for high-fidelity capstone simulations, but also for sets of verification and validation simulations.

**Possible Solution:** Leadership-class computational resources and a new INCITE-like program that would allow U.S. manufacturers to compete for time to do both high-fidelity capstone simulations and sets of verification and validation simulations. This public-private partnership would combine initial access to HPC resources supported by the federal government that would enable leading U.S. manufacturers to begin to exploit HPC resources and pay per use, once they are engaged.

**Problem:** U.S. manufacturers' intellectual property needs to be protected.

**Possible Solution:** New models should be developed that assure the protection of corporate intellectual property while still allowing companies to use leadership-class computational resources and engage in meaningful, innovation-focused, pre-competitive collaborations.<sup>3</sup> These models should allow for the use of proprietary software, collaborative improvements to proprietary software, protection of proprietary results, no publication requirement for proprietary results, etc., while requiring publication of results sufficient to demonstrate the value of the simulations and enable resources to be awarded competitively.

<sup>2</sup> "U.S. Manufacturing—Global leadership Through Modeling and Simulation," Council on Competitiveness draft white paper, 4 March 2009, p.2.

<sup>3</sup> "U.S. Manufacturing—Global leadership Through Modeling and Simulation," Council on Competitiveness draft white paper, 4 March 2009.

### Three Overseas Examples:

- HLRS, the German national HPC facility in Stuttgart, has assisted the nation's coal-fired power plant industry in using modeling and simulation to optimize plan design and operation.<sup>4</sup>
- Partnership for Advanced Computing in Europe (PRACE) allows industry to compete for access to leadership-class computing facilities while enabling them to protect their intellectual property.
- A partnership between BMW and Japan's Earth Simulator supercomputer is benchmarking optimal automotive design, safety and performance.<sup>5</sup>

### Topic B: Access to Software and Intellectual Capital for U.S. Manufacturers

The Fortune 50 HPC-intensive manufacturers are global industrial leaders. Their use of modeling and simulation enables them to compete on innovation. The federal government national laboratory system has research and production software that could be leveraged to enhance the use of HPC by the Fortune 50 manufacturers, broaden its use to the Fortune 200 manufacturers, and deepen its use down the supply chain for the competitive advantage of U.S. manufacturers.

**Problem:** Much of the modeling and simulation software currently available, either through open source or ISV software licenses, originated in codes brought out of the national labs and commercialized in the late 1960s and early 1970s. Much of it neither incorporates state-of-the-art methods nor runs efficiently at scale on current massively parallel computer architectures. Creating new software of this kind involves high risk and modest initial reward. Consequently, the market alone has not been able to address the commercial software problem for HPC modeling and simulation, as it was not able to address the hardware problem.

**Possible Solution:** New public-private models should be developed to bring into being state-of-the-art, multi-physics, multi-scale codes that run efficiently at scale on current massively parallel computer architectures, and that are robust and reliable enough, and sufficiently documented and supported, to be used commercially.

A federal program combining incentive "push" and demand "pull" might be a possible model. The program would incentivize the creation of new commercial software for HPC modeling and simulation through a competitive program that would provide funding for it. It will be important for the incentives to be equally available to commercial software vendors—partially proprietary, and partially open vendors and open source vendors—so that there is a level playing field.

<sup>4</sup> "U.S. Manufacturing—Global leadership Through Modeling and Simulation," Council on Competitiveness draft white paper, 4 March 2009, p. 1.

<sup>5</sup> "U.S. Manufacturing—Global leadership Through Modeling and Simulation," Council on competitiveness draft white paper, 4 March 2009, p. 1.

At the same time, the program would increase the market for such software to the Fortune 200 manufacturers and the supply chain for major manufacturers by establishing advanced computing service centers in each of the 50 states to provide education, training and support for smaller companies to learn how to use HPC modeling and simulation, combined with a targeted tax credit to encourage them to do it. The advanced computing service centers would help in the following ways:<sup>6</sup>

- Coordinate and increase industry access to the nation's advanced computing assets;
- Provide local professional development opportunities; and
- Facilitate discovery of advanced modeling and simulation for innovation among companies with limited or no technical experience.

#### **Proposition: National Software Alliance**

Corporate industrial leaders in advanced computer-enabled design and manufacturing should be "called to service" to leverage their expertise in modeling, simulation, analysis and partnering with the federal government to improve U.S. manufacturing competitiveness. The Alliance will be a public-private partnership that includes advanced computing users from industry, government and academia, and will address the often daunting issues surrounding software for advanced modeling and simulation. Software development for solving complex problems will require competent and innovative work on a continuous basis. Issues the Alliance will address include the following:<sup>7</sup>

- Moving legacy codes to new architectures and new machines;
- Writing new codes to accomplish new powerful capabilities;
- Formulation of new approaches to solve known problems;
- Algorithm development to convert the new formulations into viable, hardware architecture-aware codes;
- Methods to assure efficiency and scalability across a broad horizon of applications and algorithms;
- Embracing multiple cores and hierarchical processor structures in massively parallel architectures;
- Methods for verification and validation that lead to certification of codes;
- Using design methods that incorporate the reality of stochastic processes from the start; and
- New approaches to licensing and encouragement of open source software.

6 "U.S. Manufacturing—Global leadership Through Modeling and Simulation," Council on Competitiveness draft white paper, 4 March 2009, p. 3.

7 "U.S. Manufacturing—Global leadership Through Modeling and Simulation," Council on Competitiveness draft white paper, 4 March 2009, p. 2.

## **Topic C: Workforce Development for HPC Modeling and Simulation**

**Problem:** The U.S. is failing to educate and train young scientists and engineers to design, develop, and implement algorithms and codes for the massively parallel computer architectures of the present, let alone the radically new architectures of the future, and to exploit HPC modeling and simulation for verification and validation.

**Possible Solution:** A public-private partnership to educate and train young scientists and engineers to use HPC modeling and simulation on current and future architectures should be explored. DOE, NSF and other agencies should consider creating fellowship programs to train graduate students and postdocs in HPC modeling and simulation, and expanding the Presidential Early Career Awards in Science and Engineering (PECASE) program in this area. These programs could be linked to internships and summer programs at manufacturers who use or want to start using HPC modeling and simulation.

# Toward Adoption of Digital Modeling and Simulation in the U.S. Manufacturing Supply Chain

White Paper

31 August 2010

U.S. Council on Competitiveness Summit & Workshop  
The University of Chicago Booth School of Business  
Gleacher Center  
450 North Cityfront Plaza Drive  
Chicago, IL 60611

## Introduction

Computational modeling, simulation and analytics (MS&A) is a well-documented driving force behind the innovation and competitive abilities of America's leading manufacturers. Instead of relying on expensive and time-consuming design processes, these companies digitally prototype and refine their products with great speed and precision.

Now, the federal government is calling for MS&A to be an integral part of the design, testing and quality production of U.S. manufacturers. The imperative is clear: by adopting and increasing their use of MS&A, U.S. manufacturers will:

- Lower costs;
- Increase quality;
- Decrease time-to-market;
- Enhance capabilities offered in bidding; and
- Create highly-skilled technical workforces.

The U.S. supply chain can leverage the use of MS&A for competitive advantage through strategic and collaborative partnerships.

A public-private partnership is required to give all U.S. manufacturers access to this competitive tool that other countries (Germany, France, EU, South Korea, China, Japan) are providing their manufacturers. This is the best metric of the importance of MS&A technology.

## Goal

The goal of this Summit & Workshop is to produce an action plan for a new MS&A pilot for the U.S. manufacturing supply chain. A viable, sustainable business model, plan and funding must be developed. Items to be decided include:

- Type of service;
- Professional education;
- Hardware, software and middleware required;
- Startup funding needed; and
- Expertise (subject matter, computational, etc.).

The stakeholders are:

- The manufacturing supply chain that are leaders in quality, engineering and R&D;
- Original equipment manufacturers (OEMs);
- Hardware and software vendors;
- Federal government, including Department of Energy, the Office of Science & Technology Policy (OSTP) and Department of Commerce;
- Universities; and
- National laboratories.

This cross-section of interested parties will be asked to instill the mindset of a startup business into the process of understanding how to best support R&D, engineering and quality production goals of the manufacturing supply chain through MS&A.

## Output & Outcome

The Summit & Workshop output will inform a proposed pilot program to introduce and expand the use of MS&A among Midwest-based small to medium size manufacturers, the results of which would be documented and widely reported to (1) drive additional pilots in other regions, (2) inform OEMs that want to independently pursue MS&A adoption in their supply chains, and (3) guide federal policies and funding to assist the U.S. manufacturing sector.

The outcome for the proposed pilot is to achieve:

- A viable, sustainable model for MS&A national infrastructure for U.S. manufacturing;
- Successful public-private partnerships; and
- Increased productivity and competitiveness in U.S. manufacturing.

## **Requirements for Success**

All parties must communicate effectively and clearly to make this Summit & Workshop a success. Most importantly, the manufacturing supply chain must articulate their chief concerns and cost-benefit requirements for building a long-term strategy for integrating MS&A into critical levels of the American manufacturing industry. Their input into this Summit & Workshop is the most important requirement as it will be the primary driver in how planning for the proposed pilot proceeds. Likewise, the scope of the proposed pilot must be carefully crafted so as to primarily focus on the common themes of the manufacturing supply chain issues while remaining inclusive of the differences that will likely emerge. This challenge of finding the proper balance to apply to the pilot is critical to its ultimate success.

## **Known Competitive Concerns**

Fortunately, some of the competitive concerns of the manufacturing supply chain have been identified through prior studies and discussions and will be addressed during the Summit & Workshop. They include, but are not necessarily limited to:

- Lowering design and production costs;
- Enhancing product quality, reliability and safety;
- Decreasing time-to-market;
- Matching work flows with demand cycles;
- Increasing product customization; and
- Improving collaboration with OEMs.

## **Interest in Digital Modeling and Simulation**

The Summit & Workshop will likely reveal a full spectrum of existing competence and interest in MS&A. Broadly defined, suppliers fall into one of the following categories:

- No digital MS&A capability currently, but very interested in adopting;
- Minimal MS&A capability, and need additional and affordable access to software, hardware and trained personnel;
- Moderate MS&A capability, and need additional and affordable access to software, hardware and trained personnel; or
- Strong MS&A capability and want to expand its use to other areas.

## Digital Modeling and Simulation Challenges

The challenges OEMs face in optimizing the efficacy and accessibility of the necessary resources are well-documented. They include, but are not necessarily limited to:

- Acquiring software that fully leverages the latest hardware technologies;
- Decreasing barriers to MS&A tools, including commercial software and hardware;
- Increasing the integration of MS&A into product work flows; and
- Training a workforce skilled in leveraging MS&A tools.

The manufacturing supply chain is likely to have similar concerns, but may prioritize them differently or introduce entirely new considerations. For instance, suppliers are often more sensitive to issues of change than large OEMs. Technology platform shifts, for example, can paralyze and overtax firms without vast human and financial resources.

## Enabling Technologies and High Performance Computing

MS&A done on desktop computers is useful, but incapable of propelling American manufacturers ahead of their non-U.S. competitors. For that to happen, high performance computing (HPC) must be a significant part of 21st century strategies. HPC systems offer astounding benefits, as proven in various industry, government and university settings.

- **Improved accuracy:** HPC systems can deploy hundreds or even thousands, and soon millions, of processors at a single problem, turning design decisions from uncertain approximations into exact solutions. Predictive simulation is a stated goal of several large government HPC initiatives.
- **Faster turnaround:** While a complex problem may run for several days on a desktop, HPC systems can complete the same work in hours or even minutes.
- **Coupled solutions:** A desktop may be able to model one part of a larger system, but HPC systems can simultaneously model multiple parts working together in real time. Calculating the “multiphysics” all of these components working in parallel decreases design time and increases product quality.
- **Greater confidence in results:** Earning customer and government validation often requires lots of simulations to narrow the “uncertainty band” of initial results. HPC systems can perform up to and beyond 100,000x more simulations than desktops. These highly-resolved calculations provide unmatched statistical confidence.
- **Design optimization:** Only with HPC systems can engineers compare hundreds or thousands of designs in a timely and affordable manner.

Access to HPC assets is becoming easier all the time. No longer do companies need to house their own clusters and expensive IT staff specially trained in HPC cluster design and maintenance. Instead, HPC resources “in the cloud” are becoming increasingly available—and allow users to pay-as-you-go for only the resources they use. Cloud services cover a broad range of flexibility to the end user, ranging from the ability to provision raw hardware over the Internet on demand (Infrastructure-as-a-Service, or IaaS), to slightly more pre-packaged services that handle many of the details of the underlying operating systems and applications (Platform-as-a-Service, or PaaS), to complete abstraction that bundles hardware provisioning and application access and licensing in a web-based graphical interface (Software-as-a-Service, or SaaS). All of these cloud models offer a pay-only-for-what-you-use policy, and the ability to rapidly expand, contract or release provisioned resources. SaaS potentially holds the most benefit for those who are new to MS&A, yet its realization in the scientific computing domain is only in the nascent stages of development.

While cloud computing offers many benefits, it is a new and evolving technology space still in the early stages of acceptance. Understanding the challenges such as security, IP protection, reliability, storage and a host of other issues is important to any discussion attempting to weight the cost benefits.

## **Questions for Discussion**

Summit attendees should consider the following questions in advance of what will surely be a lively discussion. Likewise, your own questions are critical to the conversation.

### **Questions for manufacturing supply chain:**

- What design and production activities can be addressed with modeling and simulation?
- What benefits do you see of using modeling and simulation in your processes?
- What barriers prevent you from adopting MS&A and leveraging HPC resources?
- How would you craft a cost-benefit analysis of adopting MS&A into your processes?
- How do you effectively train your current workforce to use new technologies?
- How would you measure the effectiveness of the pilot?

### **Questions for OEMs:**

- What evidence can you provide to your supply chain that MS&A will help them achieve the ultimate goals of increased productivity and competitiveness?
- Do you have MS&A resources (e.g. hardware, software licenses, trained personnel, etc.) that you could expand or redirect in support of your supply chain?
- How would you measure the effectiveness of the pilot?

**Questions for software & hardware vendors:**

- What are you prepared to do to help broaden the market reach of your products?
- Have you considered, or are you developing, Software as a Service (SaaS) interfaces for your products?
- Would you consider bundling software and hardware in a single pay-as-you-go package?
- How scalable is your software? How are you preparing your products to fully leverage next-generation HPC technologies (e.g. massive fine-grained parallelism, extreme non-uniform memory access (NUMA) architectures, specialized accelerators, etc?)
- What level of background in MS&A do you assume your customers have in the training you provide for your product(s)?

**Questions for national laboratories, academic HPC centers and service providers:**

- How do you currently interact with private industry?
- What restrictions, if any, do you face to working with private industry?
- Do you have standard agreements in place to define licensing, royalties and IP protection issues with private industry?
- What are the primary barriers toward increasing HPC resource access to private industry?

# A Framework for a Regional Modeling, Simulation and Analysis Midwest Pilot Program for the Manufacturing Supply Chain

14 September 2010

Council on Competitiveness Summit & Workshop  
The University of Chicago Booth School of Business  
Gleacher Center  
450 North Cityfront Plaza Drive  
Chicago, IL 60611

## Introduction and Background

The Council on Competitiveness and selected original equipment manufacturers (OEMs) are developing a Midwestern regional pilot program as a public-private partnership with the U.S. federal government. The pilot program is aimed at improving competitiveness and innovation in small- and medium-size enterprises (SMEs) in the U.S. manufacturing supply chain. The ultimate outcome of the pilot program will be a workforce with enhanced technical skills, improved product quality, better customization of products, and job retention and growth.

On August 31, 2010, a Summit & Workshop was held at the Gleacher Center in Chicago that brought together representatives from a broad cross-section of industry, academia and the federal government to brainstorm ideas and to agree upon the necessary and desired components for such a pilot program. This document captures the decisions made at that meeting, and provides guidelines for implementing the pilot program.

The high level goal of this pilot program is to develop and demonstrate a sustainable, scalable and replicable model for accelerating and broadening use of modeling, simulation and analysis (MS&A) in Midwestern SMEs through a public-private partnership (described below). Funding will be provided as seed money for this pilot program, with the expectation that it will demonstrate a path toward long-term sustainability. This is only achievable if (a) the supply chain members can rapidly reach a point where the results produce cost-benefits that allow and incentivize them to continue use of MS&A, either independently or within the continued context of the pilot program, and (b) software vendors can develop a business model that provides easier and more affordable access to software tools for SMEs.

The longer term goals of this pilot program are to put U.S. manufacturing on a path toward using MS&A for digital prototyping of new and existing products and for process manufacturing. The commensurate benefits that these goals provide are outlined in the white paper developed by the Council on Competitiveness for the Chicago meeting. Also, we expect this pilot program to be a demonstration of effective coordination that will be used in the startup of other regional centers.

Figure 1 captures one dimension of the current landscape of MS&A in U.S. manufacturing. The key points are that U.S. manufacturers are at different levels in their adoption of MS&A in their processes, and that a natural progression of adoption and expertise exists to either adopt or advance usage to the next level. The focus of this pilot program is on the first two levels:

- Entry level—supply chain manufacturers who currently have no capabilities in MS&A, but recognize the benefits as a way to increase their competitive advantage.
- Advancing—supply chain manufacturers who currently have some initial capability, but want to become more advanced in their use of MS&A to promote innovation and ensure their long-term competitive advantage.

**Figure 1. Stages of MS&A Adoption**

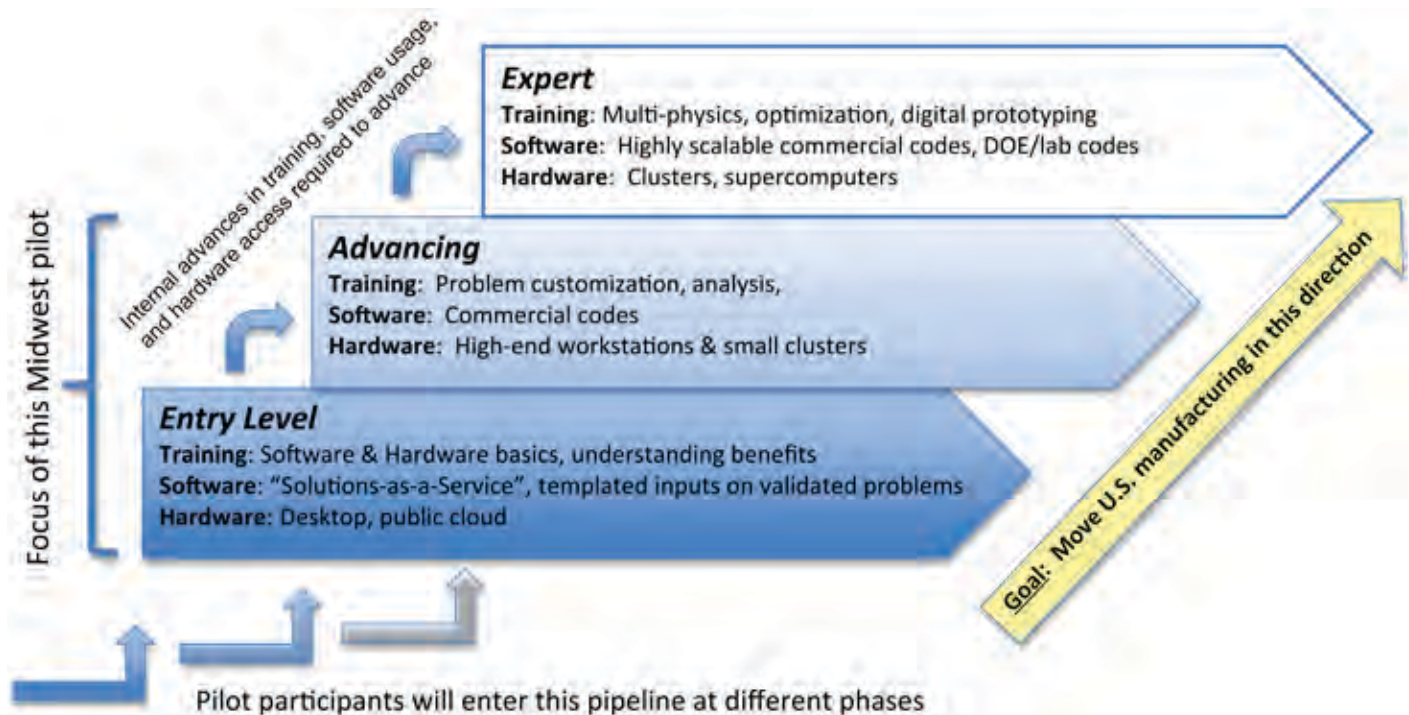

## Public-Private Partnership for the Pilot Program

A public-private partnership will be formed to create the pilot program. This partnership will include the U.S. government and selected OEMs willing to collaborate with their Midwest manufacturing supply chain members in a MS&A pilot program. The federal government will provide funding support and in-kind contributions—such as computational assets, expertise, professional education, etc.—as their contribution to the pilot program. The selected OEMs will provide in-kind contribution—such as expertise, coaching, etc. The federal government and the selected OEMs will be designated as shareholders.

The selected OEMs will identify and recruit members of their supply chain (Midwest locations) to participate in the pilot program. Some SMEs not affiliated with the OEMs may be considered for participation. The next step is to determine the operation and required funding needed for the pilot program (management, professional education, software/hardware required, delivery mechanism, etc.) that will advance SMEs use of modeling and simulation and that best support the pilot program goals.

## Goals of this Proposed Pilot Program

The stated goals of this pilot program include the following:

- Introduction of MS&A into SMEs that currently have no capabilities, or have been unsuccessful introducing it into their processes in the past.
- Advancement of MS&A beyond the entry level in SMEs who currently have existing capabilities.
- Demonstrate competitive value and cost-benefits of MS&A for typical supply chain manufacturers.
- Explore new business models based on web-based software access through cloud computing.
- Promote sustainable bi-directional knowledge transfer between OEMs and their supply chain partners (OEMs providing guidance on advanced usage, SMEs providing expertise in their specific fields).

## Essential Components of the Pilot Program

A successful realization of this pilot program will supply the SMEs with access to all of the necessary conditions for maximum success. This includes the following minimum set of core components:

**Expertise, consulting and training:** A successful pilot program will provide the SMEs with not only guidance on the benefits of MS&A, but access to expertise in the respective fields (e.g. finite element modeling, fluid dynamics, process modeling, etc.). Likewise, training geared toward the SMEs should be provided—both in the use of commercial modeling software and in the demonstration of its application through specific case studies—so that SMEs can appreciate the value proposition. This has been noted as the most important driver of success, with a strong partnership between OEMs, SMEs, independent software vendors (ISVs), national labs, universities, manufacturing consortiums, etc., driving knowledge transfer and collaboration.

**Commercial software packages:** ISVs should develop innovative licensing agreements that help lower the barriers to entry, greatly expanding market penetration—for example, pay-as-you-go services that promote the ability for SMEs to introduce MS&A at a lower initial cost.

**Platforms:** One of the key elements of this pilot program is to demonstrate software-as-a-service (SaaS) type web-based tools that are easy to access and use, including on-line education and training resources. Finally, it is understood that this pilot program, as well as any subsequent pilot programs, will have a regional focus that allows frequent interaction among participants, and exploits regional commonalities among supply chain industries and regional assets (academic, national labs, high performance computing (HPC) centers, etc). Figure 2 represents an example of how the pilot program might be realized.

**Figure 2. Example Template for MS&A Pilot Center**

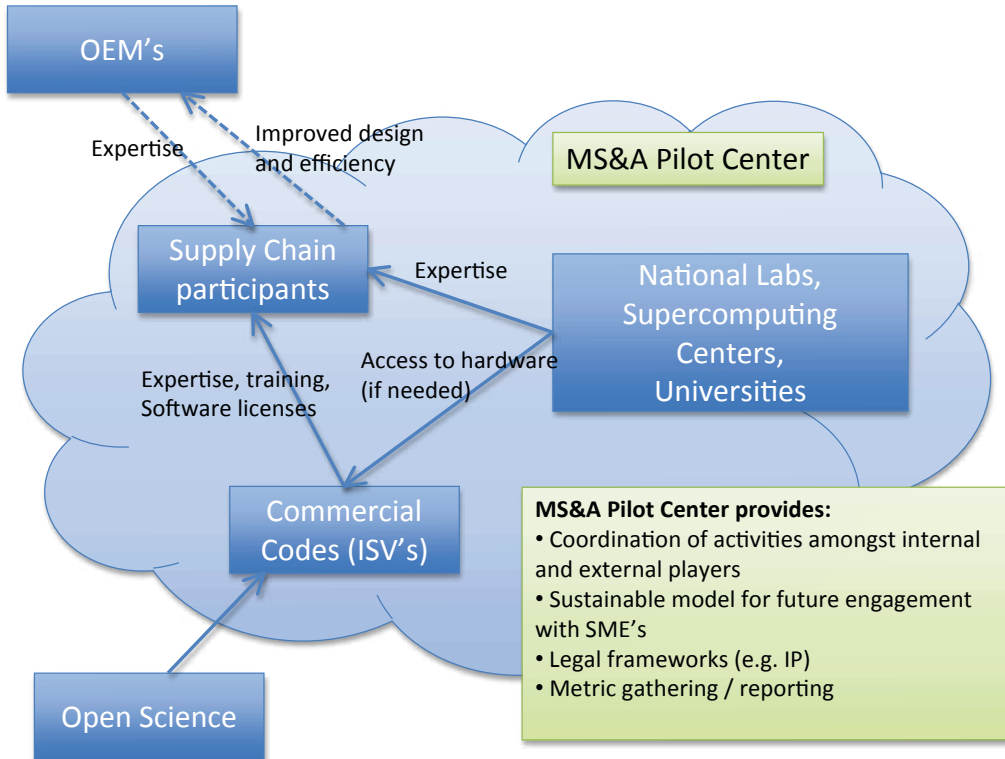

### Attributes of the Pilot Center

In addition to the explicitly stated goals defined above, a successful pilot program should take into account the following desired attributes and outcomes:

**Sustainability:** While this pilot program program will provide seed money to assist in the startup efforts of building a regional center, it will only be deemed successful if it can become self-sustaining.

**Scalability:** The scope of this pilot program will be limited to a relatively small number of OEMs and SMEs. However, the methods proposed and developed must be transferable to other SMEs at all levels of expertise, and replication of the pilot program to other regions in the United States is a required attribute.

**Metrics for success:** The successful pilot program will define measurable metrics upon which the success and sustainability of this and future pilot models can be defined/measured.

**Intellectual property and security:** Processes must be put in place to ensure that the partnerships can succeed without compromising proprietary data, products or methods of participants. This includes legal protection of intellectual property (IP), as well as a computing and networking infrastructure that is impervious to malicious attack.

**Collaborative projects:** The identification of high-value challenges of maximum benefit to both the OEMs and SMEs should be identified (e.g. design of mix tanks, injection molds, stress analysis, etc.). In addition, process flow modeling (e.g. discrete, continuous and batch simulations) should be considered.

**Domain portals and SaaS:** Development of domain specific interfaces aimed at solving a specific class of problems should be considered. This is deemed especially important in gaining adoption of MS&A in entry level organizations.

**Validation:** Providing SMEs with validated models and the expertise to analyze results is critical to helping them move to a complete digital prototyping infrastructure, where the results can replace traditional prototyping methods and expensive experimentation.

**Pay-as-you-go models:** SMEs typically do not have R&D budgets that allow them the ability to pay for commercial licenses during the time when cost-benefits are still under analysis. Providing software that allows them to pay for only the time they are running models (versus up-front license tokens) is a possible solution. Other innovative solutions are desirable as well, perhaps developed by the ISVs.

## Next Steps

It is anticipated that the U.S. government will need an integrated proposal that will include:

- An overview of the pilot program, with specific explanations of how each of the essential and desired components above is addressed. In addition, an overview of the management and organization for the pilot program and descriptions of the anticipated relationships between internal and external entities. (2–4 pages)
- Optionally, additional features not discussed in this framework description that can further promote the end goals of the pilot program. (0–1 page)
- Cost of the development and running of the pilot program for a 24 month period. (0.5–1 page)
- Explanation of long term sustainability at the end of the proposal period. (0.5–1 page)
- Brief descriptions of the partners involved. (1 paragraph each)

# Appendix C

Case studies of 10 SMEs that participated in NDEMC.



## Case Summary Report

In recognition of the longstanding leadership and commitment of the Council on Competitiveness in promoting policies related to high performance computing (HPC), the White House asked the Council to develop and launch a new industry-led supercomputing partnership to support a robust, agile and globally competitive supply-chain. The long-term vision for The National Digital Engineering and Manufacturing Consortium (NDEMC) was to create a self-sustaining non-profit entity that offers expertise, software and hardware to support small- and medium-sized manufacturing enterprises (SMEs) across the country, including the Southeast region.

The Consortium was a public-private partnership (PPP) created to promote and facilitate the adoption of modeling, simulation and analysis (MS&A) and HPC resources for SMEs and U.S. manufacturing supply chains. The partnership's core mission focused on facilitating the expertise and resources from the top Fortune 100 companies by incorporating advanced computing software and hardware resources into the U.S. manufacturing base. The Council was the leading agency behind this initiative and developed allegiances with four original equipment manufacturers (OEMs) that were instrumental in the development of the PPP business model.

Based on a framework paper from 2010, the Council envisioned a scalable model that merged the synergies between university partners and private industry to help small businesses drive HPC into their design and production operations to improve product quality, provide better customization and deliver financial growth. The initiative's main industry partners included Council stakeholders Deere & Company, General Electric, Lockheed Martin Corporation and the Procter & Gamble Company. SMEs benefit from the HPC expertise and other technology capabilities from the program's university partners, which include Purdue University, the Ohio Supercomputer Center, and the National Center for Supercomputing Applications (NCSA) at the University of Illinois, the National Center for Manufacturing Sciences (NCMS), Argonne National Laboratory and the National Aeronautic and Space Administration (NASA). NDEMC's full list of partnering institutions and organizations may be found on the [NDEMC.org](http://NDEMC.org) website.

Based on grant funding through the Economic Development Administration (EDA), NDEMC developed a Midwest Pilot program to provide the SME community with advanced computing resources to improve their production capabilities. The program had over 20 projects throughout the Midwest region of the United States, of which many are presently in various stages of completion. OEM investment and matching Federal and State of Ohio funds supported this NDEMC pilot. The long-term objective of NDEMC was to roll out a national platform that provides small manufacturers with advanced computing tools to become more competitive in the global economy; therefore, helping to broaden and grow a strong manufacturing base throughout the country.



NDEMC's value proposition was that it offered technical expertise, education, portal-based simulation software, and hands-on training to SMEs to promote the benefits and usage of HPC-related technologies in support of their business operations. The following ten SME project case summaries illustrate how NDEMC has succeeded in helping SMEs enhance their production capabilities, product innovation process and business competitiveness through their participation in the NDEMC program.

**Important note:** At the conclusion of the Midwest Pilot, these ten represented SME projects were expected to be complete. All of the case summaries were written during the course of the Midwest Pilot program between July 2012 –June 2013. Therefore, the case findings may have changed since the conclusion of the Pilot.

Every SME allocated sufficient time and personnel to complete successfully these technical projects, which required time and rapport with their OEM and/or university partner. As a result of NDEMC's Midwest Pilot, SMEs were receiving a significant return on their investment from their participation in the program. By adopting these new HPC tools into their operations, SMEs have improved their product design, reduced wasteful spending, increased new business, hired new skilled workers and improved sales revenue. Based on the results of the pilot, NDEMC has developed invaluable lessons-learned by having catalyzed MS&A resources to the benefit of the SME community.

The following summary highlights the key insights captured from SMEs participating in the NDEMC Midwest Pilot program:

- The desire of many SMEs is for a “pay-as-you-go” business model, now that they have realized the benefits of incorporating new MS&A resources into their workflow. NDEMC is developing a software-as-a-service pricing model potentially in another U.S. region to assess customer demand from the SME community.
- Defining clear and cohesive project goals from the top down was critical to an SME project's success (e.g. OEM/MEP communications with SME leadership).
- The need for significant hands-on training for skilled workers to realize fully the potential of incorporating MS&A resources into their business operations.
- The importance of “reducing time-to-market for products” was a significant factor in SMEs deciding to participate in the NDEMC program to improve their business operations.
- More strategic planning is required by NDEMC leadership to understand all the associated costs behind each SME project (e.g., there is a need for increased research validation testing).
- The Midwest Pilot was responsible for the SMEs creating more than 160 new jobs last year with a capital investment of around \$600,000.

**Employees of Rosenboom, an SME that participated in the NDEMC program, gather for a large group photo at their headquarters (below).**



## Table of Contents



*HPCwire, a reliable source for advanced computing news coverage, recognized NDEMC for its impactful collaborations between the federal government and private industry. (Shown above)*

Front (left to right): Dr. David Hudak, Program Director for Cyber Infrastructure and Software Development at the Ohio Supercomputer Center; Thom Dunning, Director of NCSA; Tom Tabor, CEO and Founder of Tabor Communications; Dr. Cynthia R. McIntyre, Senior Vice President at the Council on Competitiveness; Aaron Malofsky, Communications Program Manager at the Council on Competitiveness; and Dr. Ashok K. Krishnamurthy, former Interim Co-Executive Director of the Ohio Supercomputer Center.

Back row (left to right): Merle Giles, Director, Private Sector Program & Economic Development, NCSA; Dr. Thomas Lange, Director, R&D, Modeling and Simulation, P&G; Dr. George Adams, Director, ManufacturingHUB.org, Purdue University; Dennis Thompson, Technical Project Manager, NDEMC; Dwane Sattler, Associate Vice President for Policy, Ohio Technology Consortium, The Ohio State University; HPCwire representative; Dr. Alan Chalker, Director, Client Engineering, Ohio Supercomputer Center; HPCwire representative.

## Table of Contents

<b>Jeco Plastic Products.....</b>	<b>Page 4</b>
<b>Rosenboom Machine &amp; Tool.....</b>	<b>Page 5</b>
<b>Greenlight Optics.....</b>	<b>Page 7</b>
<b>Boss Industries.....</b>	<b>Page 9</b>
<b>Dekker Vacuum Technologies Inc.....</b>	<b>Page 11</b>
<b>AltaSim Technologies Inc.....</b>	<b>Page 13</b>
<b>Adams Thermal Systems.....</b>	<b>Page 15</b>
<b>KLW Plastics.....</b>	<b>Page 16</b>
<b>Technology Management Inc. (TMI).....</b>	<b>Page 18</b>
<b>Engendren Inc.....</b>	<b>Page 20</b>

## Jeco Plastic Products, LLC

Plainfield, IN

[jecoplastics.com/](http://jecoplastics.com/)

Partnered with Purdue University and Ohio Supercomputer Center for the project



**Background:** Jeco Plastic Products, LLC is a small custom-mold manufacturer of large, complex, high-tolerance products with a plant in the Indianapolis area. Two processes are used in the manufacturing facility—rotational molding and twin-sheet pressure forming. Materials used range from commodity thermoplastic resins, such as polyethylene (PE), to extraordinarily difficult resins, such as polyetherketoneketone (PEKK) with continuous unidirectional carbon fibers. Jeco’s customer base includes large U.S. and international original equipment manufacturers (OEMs) in the automotive, aerospace, printing and defense industries. For more information, visit the company’s web site at [jecoplastics.com](http://jecoplastics.com).

**Project Summary:** NDEMC provided access to expert staff at the Ohio Supercomputer Center (OSC) and Purdue to enable Jeco engineers promptly analyze and address a potential customer’s last-minute design changes to a Jeco pallet product. Without the expertise and high performance computing (HPC) modeling, simulation and analysis (MS&A) resources, Jeco would have lost the opportunity for a multi-million dollar export order to a German OEM. NDEMC provided the engineering workforce training on ABAQUS software, used to analyze the pallet design change. Jeco’s demonstrated capabilities with ABAQUS and HPC are helping to pave the way for larger, high profile clients. **Project Completion Status: 100%.**

**Expected Technology/Economic Impact:** NDEMC’s engagement created a new opportunity for a multi-year contract with annual orders of \$2.5 million during the next five to ten years. In addition, Jeco is expected to increase payroll with the hiring of fifteen new skilled-workers and a capital investment of more than \$500,000. Based on current projections, Jeco management is expecting a reasonably steady increase in cumulative sales revenue for rotational molding between 2013 and 2022, totaling nearly \$23 million during the period. This projection is based on a full-scale release of a new product for their German OEM customer. This product is in world-wide field trials now. From a global competitiveness perspective, Jeco’s demonstrated experience with MS&A during the Midwest Pilot project was instrumental in helping them secure additional high profile projects for aerospace and automotive clientele.

The company also received a lucrative order from NASA for a major component for the International Space Station based upon upon their ability to design and manufacture products layered anisotropic materials with continuous internal fiber reinforcement.

(Below: Modeling simulations of Jeco’s inner pallet construction)

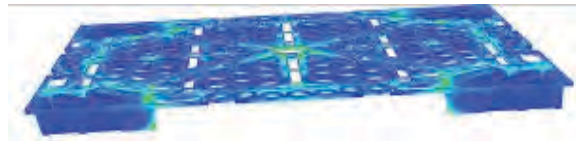

## Rosenboom Machine & Tool

[www.rosenboom.com](http://www.rosenboom.com)

Sheldon, Iowa

Partnered with Deere & Co. and NCSA for the project



**Background:** Rosenboom, Inc. of Sheldon, IA, is a family-owned company that was founded in 1974 as Rosenboom Machine & Tool by Lary and Viv Rosenboom. Today, the company has over 800 employees, with sons Brian, Darin, Justin, and Brandon actively involved in the daily operation of the business. Rosenboom engineers and manufactures custom hydraulic cylinders for industry leaders in construction, refuse, agriculture, fire rescue, transportation, forestry, military, and several other industries.



**Rosenboom hydraulic cylinders are robotically welded for consistency and integrity**

**Project Summary:** At the beginning of the project, Rosenboom had an inability to model and accurately predict the life expectancy of weldments resulting in physical testing. This contributed to significant delays in the design process, manufacturing (due to retooling for problems found) and lab time for testing purposes. A team was developed comprising: Darin Rosenboom, Kelly Greenfield, and Dean Reinking (Rosenboom); Mohamad El-Zein, Eric Johnson, Kuen Teh, and Emily Horn (John Deere); and Seid Koric (National Center for Supercomputing Applications) to solve this problem using a pilot project focusing on fatigue analysis of a cylinder cap weld joint. **Project Completion Status: 100%.**

**Custom engineered hydraulic cylinder for steering of an agricultural field sprayer (John Deere sprayer produced in Des Moines Works)**



Two FEA models were developed using Abaqus software, and the more refined model was able to simulate the stress concentration on the cap weld joint with more than 40 million degrees of freedom.

Based upon the results of using a 196 central processing units (CPU) core run on the iForge system<sup>1</sup> at NCSA, a low cycle fatigue analysis was successfully performed, with physical fatigue testing confirming the findings. These tests showed the ideal geometry to be used for weld joint preparation. The project with Rosenboom is completed, with most of the work being done and reported out by November, 2011. Deere and Rosenboom are currently doing a follow-up project involving a computational fluid dynamics (CFD) simulation to determine the flow characteristics in their products. This will further cut down on trial and error design and correlate design iterations with modified flow characteristics. This new project is in its initial stages and is expected to be finished by the end of 2013.

**Expected Technological/Economic Impact:** The design process timeline was drastically reduced for Rosenboom cylinders. While the company relied on trial and error before, these FEA tools have enabled the Rosenboom team to design their products virtually. Rosenboom's new designs will result in a significant reduction in time-to-market for their cylinder products. Leadership decided to allocate more monetary resources for MS&A to enhance their competitiveness in the marketplace. This executive decision will result in improved quality and reliability of its product line for their clientele. The company has hired more than 150 employees since the NDEMC's project initiation. By employing these advanced computing resources into their production capabilities, the design and testing times have been reduced from months to weeks. Rosenboom has been successful in competing in the global marketplace, with 5% of \$140 million in revenue coming from their industrial exports.

---

<sup>1</sup> iForge, the high-performance computing system designed for NCSA's industry partners, is being upgraded with new processors and increased capacity

## Greenlight Optics

Loveland, Ohio

[www.greenlightoptics.com/](http://www.greenlightoptics.com/)

Partnered with Lockheed Martin,  
Manufacturing and Polymer Portal and  
Ohio Supercomputer Center for the project



**Background:** Greenlight Optics designs and manufactures custom optical modules for clients in the medical, industrial, consumer, security, and lighting industries. This SME has over 250 years of experience designing, developing, and manufacturing optical systems for consumer and professional markets. The Greenlight team’s mission is to create new optical applications and provide outstanding service to its customer base.



(Above: Greenlight Optics engineer molding plastic optics)

**Project Summary:** In working with NDEMC, Greenlight has experienced personnel and the equipment required for molding optics product line. The SME was specifically seeking to improve its capabilities for designing molds and molding processes that achieved first-shot quality and bolster their competitiveness for molding optics in high volume.

Specific project activities included the following:

- Received training on the use of Moldex 3D mold simulation software
- Implemented cloud based simulation through the Manufacturing and Polymer Portal with engineering and software interface at Greenlight in Loveland, Ohio, and supercomputer processing at OSC in Columbus, Ohio.
- Conducted mold simulation on several new projects using the Portal’s “pay by the week” business model

**Project Completion Status: 100%**

**Expected Technology/Economic Impact:**

- 1) Improved capability for molding precision plastic optics traditionally produced in glass
  - Immediate Impact: New job resulting in a part-time hire and \$100,000 in new business.

- Future Impact: Advanced capability positions Greenlight to win more high-tech projects and deliver this capability to U.S. companies; therefore, improving the global competitiveness of U.S. companies.
- 2) Reduced cycle time for a high volume lens in a consumer application
- Immediate Impact: Greenlight was able to retain a production job that was originally targeted to be made in China following pilot production at Greenlight. In 2013, this will result in one full-time hire.
  - Future Impact: The ability to achieve cycle time reduction via mold simulation enables Greenlight to be competitive on volume production; therefore, keeping the optical component manufacturing in America.

Greenlight's advanced plastic optics molding capability (including simulation strengthened by NDEMC) will fuel sustainable growth. At the start of NDEMC in early 2012, Greenlight had 11 full-time employees. Greenlight is targeting 20 employees by 2015.

**Boss Industries, Inc.**

LaPorte, Indiana

[www.bossair.com](http://www.bossair.com)

Partnered with Purdue University for the project

**Background:** Boss Industries positions itself as a market leader in Power Take-Off (PTO) and Rotary Screw Air Compressor technology. The company accounts for more than 60% of all PTO rotary screw compressor sales. Boss Industries continues to expand its services as it has ventured into new markets such as railroads, mining, and construction. They produce brand name systems in these markets for major producers of service vehicles, such as IMT, Morse Industrial, and Auto Crane. Boss Industries' mission is to provide unparalleled quality, integrity, and superior design for our customer base.



The SME specifically designs, manufactures, and services a full line of vehicle integrated compressors, generators and welders. Its primary purpose is to integrate them into the drive train and chassis of the customer's utility truck.

**Project Summary:** Boss wants to expand their addressable market by reducing the size of the current air/oil separator tank, a 25-year-old design, so that their compressor systems can be installed on smaller trucks than presently available today. They entered into the NDEMC program to access faculty who specialize in aeronautics research efforts and computational methods.

To support the SME's research efforts in 2013, a Purdue faculty member in Aeronautics and Astronautics and the Director of Purdue's ManufacturingHUB.org, measured the material properties of the compressor lubrication oil, designed and developed a user-friendly software application that performs flow analysis of both air and oil. As a result, Boss Industries engineers today are simulating the performance of various and smaller separator tank designs to decide what to manufacture. **Project Completion Status: 100%.**

**Expected Technology/Economic Impact:** The NDEMC simulation is faster and cheaper than the typical usual time – six weeks to custom build a given prototype tank – and expense to conduct trial and error

experiments with many physical prototypes. Boss Industries Engineer Ben Martinsen is currently using the application and has already achieved valuable results on the compressor oil cooler tests. The shortened development lead time and improved final product performance are essential to both expand business opportunities and conform to federal regulatory requirements.

## Dekker Vacuum Technologies



Michigan City, IN

[www.dekkervacuum.com](http://www.dekkervacuum.com)

Partnered with Purdue University for the project

**Background:** Based in a 45,000 square foot facility, Dekker designs, manufactures, and distributes vacuum pump systems and equipment. Since their inception in 1998, they have been a supplier of liquid ring vacuum pump systems and equipment. Over the past several years, the company has grown to be one of the top suppliers in the industry. In 2007, Dekker was listed on the *Inc. 5000 List of America's Fastest Growing Companies*.

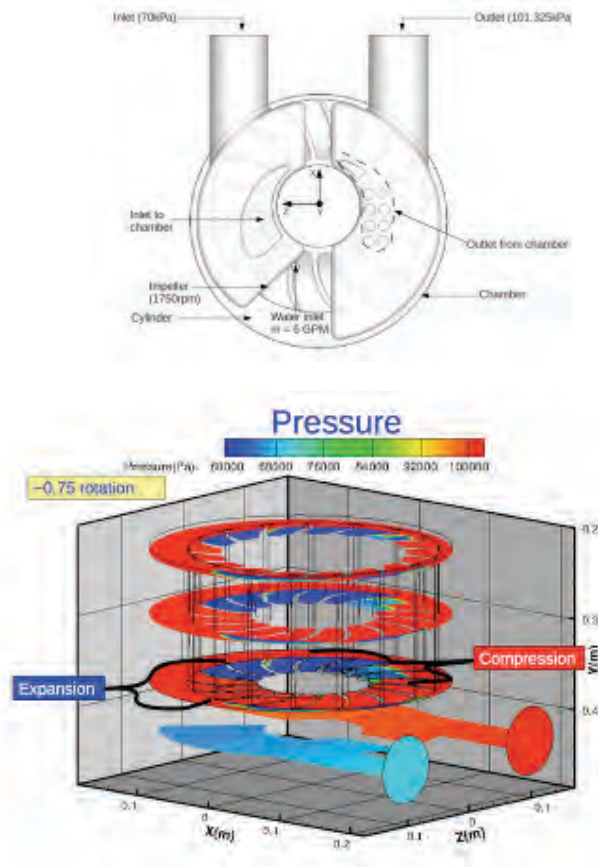

**Pump design (top) shown face on and simulation results (bottom)**  
with the pump oriented face down, to facilitate viewing three  
cross-sections of the flow within the pump body.

Working with NDEMC, Dekker wanted to understand the overall flow dynamics and flow regimes of the liquid ring pump to improve pump performance and energy efficiency. By innovating the design of the liquid pump, Dekker will be more competitive in the global marketplace for these devices.

A Purdue faculty member in Aeronautics and Astronautics and her graduate student are working with Dekker engineers to prove out the use of a commercial simulation software package available through Purdue's participation in the NDEMC program to accurately model the performance of the liquid ring pump. This design has not previously been analyzed via simulation. **Project Completion Status: 65%**

**Expected Technology/Economic Impact:** Creating a more efficient pump that uses less energy should increase market share for Dekker. Both the technology and economic impact assessment is being reviewed at this time.

## AltaSim Technologies

Worthington, Ohio

[www.altasimtechnologies.com/](http://www.altasimtechnologies.com/)

Partnered with Ohio Supercomputer  
Center for the project



**Background:** Based in Worthington Ohio, AltaSim Technologies provides specialized services to help their customers develop innovative and cost effective solutions to improve their products and processes. Since its inception in 2002, AltaSim has allowed their customers to explore, develop and apply alternative solutions without the delays and expense associated with traditional testing and evaluation by harnessing its engineering technology and advanced computational and multiphysics analytical capabilities.

**Project Summary:** AltaSim's experience in performing complex multiphysics is predicated on computational analyses, which enables the company to analyze the complex combinations of technology required in today's new products and processes. AltaSim's consulting services demonstrated savings for new technology development up to 90% of the time and up to 50% of its current cost. To increase the effectiveness of this advanced computational simulation, AltaSim has developed analytical software to allow practicing engineers with limited or no knowledge of computational analysis to develop and solve specific problems using advanced multiphysics simulations.

These software design tools provide simplified interfaces that control the input, problem set up and solution of specific multiphysics based problems. To further the application of advanced multiphysics analysis for new technologies, AltaSim also initiated focused and effective training courses so that their customers can implement their own technical solutions on a daily basis. NDEMC resources utilized included the ANSYS-ICEPAK<sup>2</sup> used on OSC's HPC platform. **Project Completion Status: 100%**

(Image below is an example of Electronics Cooling Technology)

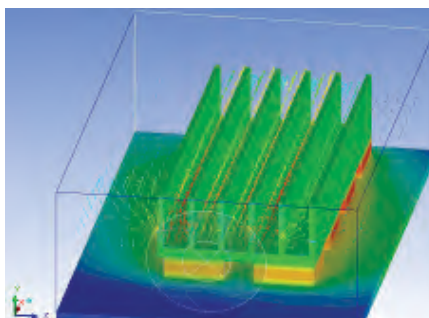

---

<sup>2</sup> ANSYS offers engineering simulation solution sets in engineering simulation that a design process requires. Companies in a wide variety of industries use ANSYS software. The tools put a virtual product through a rigorous testing procedure before it becomes a physical object.

**Expected Technology/Economic Impact:** Demand for electronic devices with smaller sizes and improved processor and graphics functionality has resulted in higher power density therefore increasing the heat generated at the component, board and system level. The higher operating temperatures can cause a significant reduction in the operating lifetime of electronic devices. As a result, managing the evolution, distribution and dissipation of thermal energy in electronic components and circuits is important to ensure long-term reliability.

In the work performed on the NDEMC program, AltaSim used ANSYS-ICEPAK to specifically evaluate the thermal behavior of new designs of printed circuit boards for use in the process control industry.

To achieve the required scale and level of accuracy, the Company had to incorporate large numbers of components to achieve simulation of the full printed circuit board (PCB) and include a significant level of detail in both the board and surroundings such that the size of the model escalated significantly. To allow them to analyze the behavior within a reasonable length of time, generally considered to be < 12 hours analysis time, AltaSim had to make use of HPC based systems. The decreased time for completion of analyses allowed them to consider different designs rapidly and make design recommendations for improved product performance that would otherwise not have been possible. As a consequence, final designs for operational components that have significantly improved product performance were developed.

AltaSim's large OEM client, Rockwell Automation, inherently benefited from the SME's new product innovation by helping them maintain a leadership in the competitive global automation arena. The NDEMC project had an impact on development of new technology; however, direct economic benefit is not quantifiable at this point. The work provided time savings in the development process of ~3 months.

## Adams Thermal Systems

Canton, South Dakota

[www.adamsthermalsystems.com/](http://www.adamsthermalsystems.com/)

Partnered with both Deere & Co. and NCSA for the project



**Background:** Adams Thermal Systems (ATS) of Canton, SD, is a manufacturer of engine cooling systems for off-highway and on-highway vehicle applications. ATS manufactures cooling modules, radiators, charge air coolers, oil coolers, fuel coolers, and condensers.

**Project Summary:** One of the major challenges with using virtual engineering in the design of charge air coolers (CACs) is that there is a computational fluid dynamics (CFD) component, which takes significant HPC resources. Initial CFD analysis, completed in November 2012, was problematic since the surface geometry inside the CAC was too complex, and it was impossible to complete FEA meshing<sup>3</sup> with such an irregular internal surface. The next step was to get a cleaner computer-aided design (CAD) drawing, with a more rationalized and simple internal geometry, so that CFD could go forward. While this was being done, ATS personnel was trained on FEA and CFD tools, which was completed in January 2013.

Last month, a clear CAD drawing was delivered, and CFD meshing was completed, although the task was using the upper limit of the solver running on a multi-core platform the CFD analysis needs a tighter mesh refinement, with about 80 million elements). This job is queued to be run through HPC resources during the spring. Concurrently, FEA mesh is being created as well.

Unlike many engineering challenges, design of cooling systems is unique in that a CFD analysis needs to be completed first. This is due to the fact that the air changes temperatures, and therefore, its properties change, as it moves through the CAC. The results of the CFD analysis will be used to map the temperature variations into the FEA model. The development of two separate models, and the informational interchange between them, adds another layer of complexity to the task. The FEA is expected to be solved before the end of the month. A structural analysis will then be used for fatigue analysis. The expected result from this NDEMC project is for the SME to implement HPC resources to create faster and more accurate designs for CACs and other ATS products. *A successful outcome would reduce product design time from months- to simply a matter of days. This would represent cost savings in the product development process.* **Project Completion Status: 75%.**

**Expected Technology/Economic Impact:** ATS will develop a durability analysis of a CAC System that can be done in a matter of hours and does not require time consuming and expensive physical testing. This NDEMC research project will enable the company to design and optimize their systems more effectively, reduce costs; at the same time, delivering a superior product to their customer base.

---

<sup>3</sup> The subdivision of the object into a contiguous set of finite elements connected together by nodes is called a finite element mesh. Note that size of the finite elements can vary spatially; smaller elements (higher element density) are often used to improve the accuracy of FEA solution in regions where the stress gradients are predicted to be high.

**KLW**

Cincinnati, Ohio

<http://www.klwplastics.com/>

Partnered with Ohio Supercomputer Center for the project



**Background:** The SME was founded in March 2005, with the vision to fulfill the need for outstanding quality and on-time logistics in the plastic tight-head container market. The KLW Plastics team indicates that their state-of-the-art manufacturing technology, R&D efforts, product design, raw material sourcing, production process and testing help contribute to developing consistently reliable final product for their customers. Their overall mission is to manufacture quality plastic tight-head containers, which are both competitively priced and produced in the most sophisticated advanced manufacturing facilities in the industry.

The NDEMC program built upon and fully validated the virtual top-load pressure, drop tests using current production in KLW packaging. Based on KLW's strategic business goals, executives utilized NDEMC's access to advanced compute resources for these validation testings. The long-term benefit of these simulations would be to (1) utilize these resources prior to cutting new molds and (2) predict the performance for packaging using different material processing. Both strategic goals from this project will lead to potential cost savings for the company by reducing the weight of the containers.

(Below: an example of KLW containers)



**Project Summary:** The engineering team at KLW needed to understand consumer complaints with KLW's bottle and the variability of the current product packages. This required X-RAY or computerized tomography (CT) data and physical test results.

Finite element models were conducted with the assistance of Kinetic Vision and Ohio Supercomputer Center. Cincinnati-based Kinetic Vision offers full product development services for its global portfolio of customers including the deliverables of concept ideation and industrial design, prototype development, product design and engineering, custom software development and reverse engineering. The first phase of the project was completed in January. **Project Completion Status: 100%.**

**Expected Technology/Economic Impact:** KLW's objective will be to reduce its weight while maintaining strength of the container products and reduce costs. More efficient use of materials, higher quality and lighter weight containers this will result in cost savings for the company and will directly

impact the SME's bottom line profit potential.

### Technology Management Inc. (TMI)

Cleveland, Ohio

**Website:** N/A

Partnered with both Lockheed Martin and Ohio Supercomputer Center for the project



**Background:** Technology Management Inc. (TMI) is a privately held Cleveland company, whose mission is to commercialize proprietary solid oxide fuel cell (SOFC) systems. Their platform technology supports applications in multiple stationary military and mobile markets. Some of the unique features of their technology include tolerance to sulfur in fuels, operation on multiple heavy liquid and biofuels and “on-the-fly” switching between multiple liquid and gaseous fuels. The company has a 10,000-square-foot development facility dedicated to creating the fabrication and testing of solid oxide fuel cell (SOFC) systems<sup>4</sup>.

In working with OSC and Lockheed Martin, three dimensional CAD models generated by TMI were used as the basis of dynamic flow and temperature modeling for two key components of the fuel cell technology platform: the fuel cell stacks and the overall hot subassembly. The TMI Fuel Cell hot subassembly, which includes the fuel cell stacks, is a complex device, which requires thermal, chemical, electrochemical, mechanical, and electrical operational optimization essential to improve performance for product introduction.

**Project Summary:** The net result from the SME project will include improved product performance and reliability, decreased time-to-market introduction, with accelerated manufacturing job creation and accelerated market expansion. NDEMC models were prepared for both fuel cells and hot subassemblies to help optimize performance through iterative simulation of various flow and geometric factors associated fuel cell operation.



(Image above: an example of a TMI Fuel Cell system)

At the present time, the NDEMC models prepared and tested by staff from the Ohio Supercomputer Center (OSC) have been used to improve understandings that could not be obtained through experimental methods. Individual fuel cells were modeled to determine the impact of imperfections in the fabrication process on cell and stack performance. The data from these simulations have been used to modify TMI’s fabrication process and component specifications to help improve reproducibility and performance. TMI is currently testing these improvements; and preliminary findings have shown promising results. This will result in the broad commercial application in multiple markets through the application of the TMI system platforms. By utilizing NDEMC’s advanced compute resources through its solution partners, the

<sup>4</sup> An electrochemical conversion device that produces electricity directly from oxidizing a fuel. Fuel cells are characterized by their electrolyte material; the SOFC has a solid oxide or ceramic, electrolyte. Advantages of this class of fuel cells include high efficiency, long-term stability, fuel flexibility, low emissions, and relatively low cost. The largest disadvantage is the high operating temperature which results in longer start-up times and mechanical and chemical compatibility issues

company is confident it will achieve both its technology and production goals so they may remain competitive in the global markets. **Project Completion Status: 80%.**

**Expected Technology/Economic Impact:** The NDEMC project will enable the company to develop manufacturing processes utilizing more appropriate fabrication metrics and component specifications, thereby improving overall product quality and reliability. In addition, system modeling has provided design insights that were only obtainable previously by a more time consuming and costly design-build-test-evaluate cycle. Thus this project will enable TMI to optimize system designs more effectively, reducing costs and shortening the development timeline.

The expected completion date of the project is Fall 2013. TMI is currently in the product development phase prior to commercial introduction.

## Engendren Corporation

Kenosha, Wisconsin

[www.iearad.com](http://www.iearad.com)

Partnered with Ohio Supercomputer Center  
for the project



**Background:** Engendren Corporation designs and manufactures industrial copper/brass and aluminum radiators and charge-air coolers (R&CAC). During this operation, the R&CACs are subjected to transient pressure and thermal cycle loads. It has been observed that while the SME's products meet the performance requirements at steady state, they mostly underperform when used in transient conditions. The R&CAC heat exchangers are made out of copper/brass and aluminum and are brazed at elevated temperature. Under cyclical conditions, the tube-to-header joints and heat affected zones develop cracks which lead to deterioration of performance and reliability.

**Project Summary:** Engendren seeks to enhance the quality of their product line by ascertaining the root causes of product failures and how the thermal cycle and pressure cycle conditions affect the performance. Using MS&A resources, Engendren wants to identify the failure mechanisms, critical design parameters, material properties and develop new products that will withstand the steady state as well as transient application conditions.

Based on the Company's internal computational needs assessment, the executive team recognized that HPC-related tools are imperative for this type of simulation and require considerable knowledge, experience and monetary resources. In addition, complex multi-physics testing requires substantial amount of advanced computing power to solve the problems in a reasonable time-frame. With the expertise and training from OSC, the Engendren team gained access to M&S software and hardware to solve these complex problems.

With use of MS&A, the SME utilized advanced compute resources to conduct computational fluid dynamics (CFD) to simulate flow dynamics and conjugate heat transfer in the current R&CAC products. These analyses would be coupled with finite element analysis (FEA) to determine stresses that are due to transient pressure and thermal loading conditions based on the output of the CFD study. Based on these two analyses, Engendren employed HPC resources to determine the appropriate tube configuration to show the best heat transfer performance. By identifying design to be developed based on reliable data, they can predict the best performance and reliability for future production requirements. **Project**

**Completion Status: 50%.**

**Expected Technology/Economic Impact:** Engendren seeks to expand and improve product line to achieve sustainable growth to their business model. Through hands-on training with these advanced compute resources, they seek to design and develop new products that can withstand the severe application requirements. The long-term business impact will include the potential to expand into new markets and become more competitive domestically. The project is approximately at the halfway stage of their timeline and its expected completion date will be in the early portion of the summer.



**Council on Competitiveness**

900 17th Street, NW, Suite 700, Washington, D.C. 20006 T 202 682 4292

[Compete.org](http://Compete.org)



**Compete.**

Council on  
Competitiveness